

September 2019

# CAN Newsletter

*Hardware + Software + Tools + Engineering*



*"The data processing moves  
into the edge"*

*Encoders for hydraulic and telescopic cylinders*

*Swedish shopping center with  
CANopen-Lift control system*

[www.can-newsletter.org](http://www.can-newsletter.org)

*Interviews*



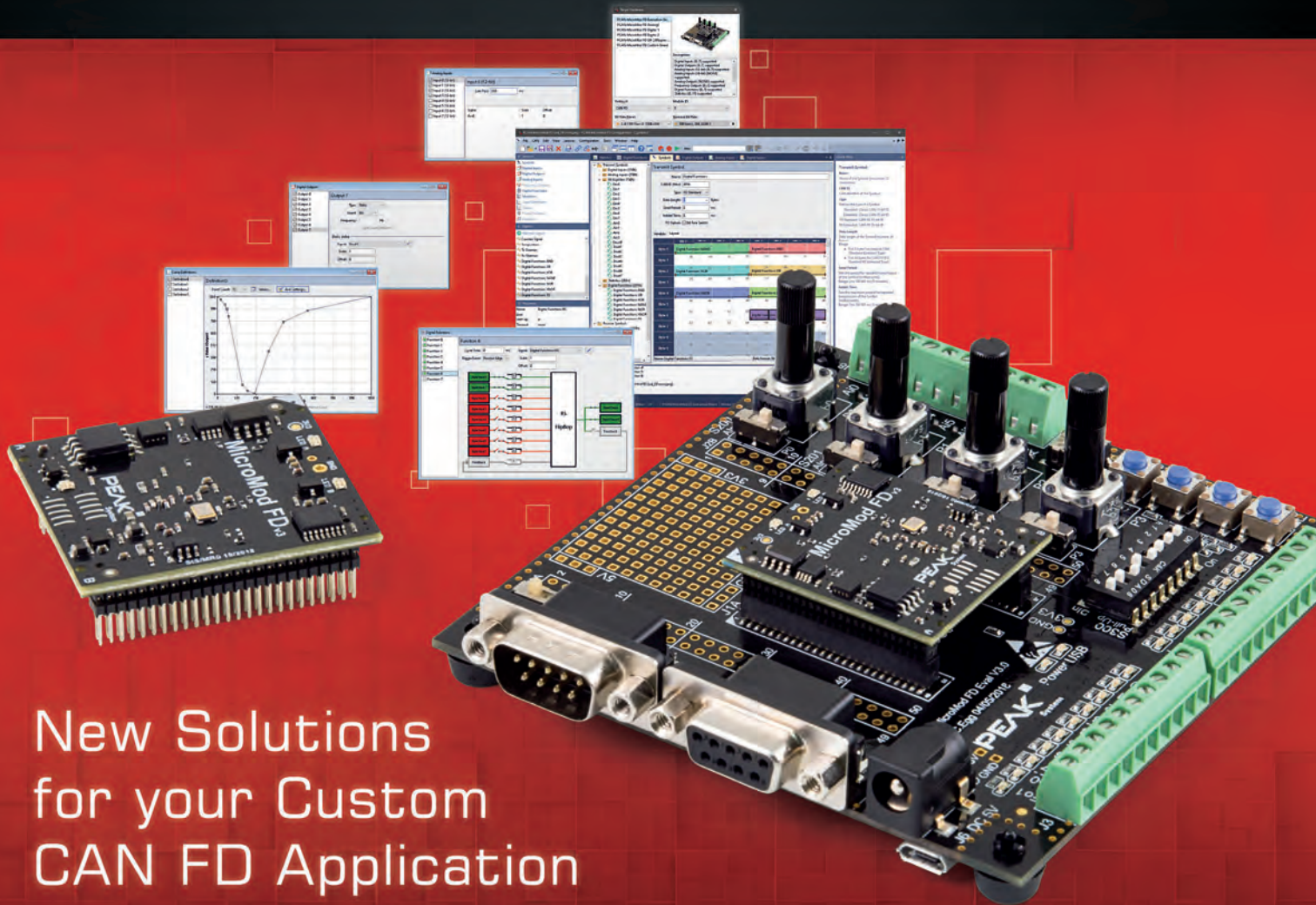

# New Solutions for your Custom CAN FD Application

## ■ PCAN-MicroMod FD

New product line with CAN FD interface and I/O functionality

The PCAN-MicroMod FD is a small plug-in board which provides a CAN FD connection and enhanced I/O functionality for the integration into your hardware. An evaluation board facilitates the development of your custom solution.

The module is configured with a Windows software via the CAN bus and then operates independently. In addition to simple I/O mapping to CAN messages, function blocks are also available for processing the data.

Besides the evaluation board, the PCAN-MicroMod FD will also be available ready-to-use mounted on small motherboards that provide peripherals for specific applications.

### PCAN-MicroMod FD:

- NXP LPC54618 microcontroller
- 1 High-speed CAN connection
  - Complies with CAN specifications 2.0 A/B and FD
  - CAN bit rates from 20 kbit/s up to 1 Mbit/s
  - CAN FD bit rates from 20 kbit/s up to 10 Mbit/s
  - Microchip CAN transceiver MCP2558FD
- 8 digital inputs and 8 digital outputs
- 2 frequency outputs

- 8 analog inputs
  - Measuring range unipolar 0 to 3 V
  - Resolution 12 bit, sample rate 1 kHz
- Selective configuration of up to 16 devices in a CAN bus
- Voltage supply 3.3 V
- Dimensions: 33 x 36 mm
- Extended operating temperature range from -40 to 85 °C (-40 to 185 °F)

### PCAN-MicroMod FD Evaluation Board:

- CAN bus connection via D-Sub, 9-pin
- Switchable CAN termination of 120 Ohm
- Pick-offs for all plug-in board pins
- Low-side switches for digital outputs
- DIP switches for status change of the digital inputs
- Protected digital inputs
- LEDs for digital inputs and outputs
- 4 potentiometers for analog inputs
- Soldering fields for individual additional wiring
- RS-232 connection with V.24 levels
- Firmware upload via CAN, USB, RS-232
- Reset button for restarting the board
- 5 V supply via Micro-USB or supply unit
- Board 100 x 102 mm with rubber feet



[www.peak-system.com](http://www.peak-system.com)

Take a look at our website for the international sales partners. Scan the QR code on the left to open that page.

PEAK-System Technik GmbH

Otto-Roehm-Str. 69, 64293 Darmstadt, Germany  
Phone: +49 6151 8173-20 - Fax: +49 6151 8173-29  
E-mail: [info@peak-system.com](mailto:info@peak-system.com)

**PEAK**  
System



## Interviews

"The data processing moves into the edge"	12
Encoders for hydraulic and telescopic cylinders	32
Swedish shopping center with CANopen-Lift control system	34

## Imprint

### Publisher

CAN in Automation GmbH  
Kontumazgarten 3  
DE-90429 Nuremberg

[publications@can-cia.org](mailto:publications@can-cia.org)

[www.can-cia.org](http://www.can-cia.org)

Tel.: +49-911-928819-0

Fax: +49-911-928819-79

### CEO

Reiner Zitzmann

AG Nürnberg 24338

### Downloads June issue:

(retrieved August 21, 2019)

4010 full magazine

### Editors

[pr@can-cia.org](mailto:pr@can-cia.org)

Cindy Weissmueller (cw)

Holger Zeltwanger (hz)

(responsible according to the press law)

### Layout

Nickel Plankermann

### Media consultant

Gertraud Weber

(responsible according to the press law)

### Distribution manager

Gertraud Weber

### © Copyright

CAN in Automation GmbH



## Devices

CAN-based monitoring system for spindle bearings	4
CANopen motors in automated guided vehicles	10
From "maker" PC to industrial computer	20
Slip rings connect reliably CAN bus-lines	44



## Engineering

Smart-bridging CANopen and CANopen FD	6
Partner program with quality label	24
"The trend is to go to open platform telematics"	26
Four elevators controlled by CANopen Lift	36
Designing a drive system is an interdisciplinary approach	38
Status summary of CAN security specifications	42



## Semiconductors

Ethernet links CANopen domain controllers	16
Galvanic-isolated CAN FD transceivers	28

## CAN Newsletter Online

Our sister-publication, the [CAN Newsletter Online](http://can-cia.org), is a unique source of CAN-related product information. In order to fulfill our chronicle duty, we need your support. Besides receiving company official press releases about new CAN products, we would appreciate also information about products under development or in the pipeline. We like to report about those products, which are not yet available.

In the last few month, we detected an increasing interest in CAN products supporting J1939-based higher-layer protocols. If there are more topics, in which you are interested, please inform us by email ([pr@can-cia.org](mailto:pr@can-cia.org)). We try to serve our readers as good as we can. But we need to know what you are interested in, because we are not mindreaders.

The CAN Newsletter Online also reports briefly about CAN network applications. In particular, we are interested in not state-of-the-art applications: the stranger, the better. They could also just be funny.

Your editing team: Nickel Plankermann, Cindy Weissmueller, Holger Zeltwanger



# CAN-based monitoring system for spindle bearings

*Schaeffler's Spindle-Sense monitoring system reduces downtimes and increases utilization of machine capacity. The variant C-A1 outputs the measurements via CAN.*

The main spindle is crucial to the performance capability of the complete machine tool. It is at the heart of the machine and largely defines the achievable cutting capacity, surface quality, and precision. In turn, the spindle bearing support is one of the most heavily loaded components because it must transmit machining forces precisely at very high speeds for long periods of time and the risk of collisions can never be ruled out. It therefore comes as no surprise that the majority of machine tool downtimes can be traced back to defective spindles, particularly as a result of collisions and continuous, undetected overloads. In milling operation, for example, the combination of high radial loads, long tool protrusions, and high speeds leads to particularly high loads and unfavorable kinematic conditions on the spindle bearing in the vicinity of the tool. These unfavorable and in some cases impermissible loads occur because operators have hitherto not had a suitable tool, with which they could monitor borderline loads on spindle bearings. Schaeffler has now solved this problem with its new Spindle-Sense monitoring system.

## Ready for volume production

The first production-ready SRS sensor ring units, including radial and axial measuring ring, with an inside diameter of 70 mm is available for customers to test in practical applications to coincide with EMO 2019. Additional sizes with inside 80-mm and 100-mm diameter will be available at the end of the year. All units have a standard width of 16 mm. The scope of delivery includes an SST setup service tool, with which the product can be parameterized and put into operation.

The sensor system integrated into the spindle bearing measures the displacement of the spindle shaft under load in a very high resolution and in five spatial directions – three translational and two rotatory. The sensor ring transmits an electrical warning signal to the machine's control system if the deflections measured on the rolling elements exceed a specific threshold, which is set individually for every spindle and machine type. The threshold is based on an assessment of operation-related bearing parameters such as pressure, spin/roll ratio, and cage pocket clearance, into which Schaeffler has integrated its many years of expertise in rolling bearings.

All of the software and the required algorithms are integrated into the 16-mm sensor ring. No further components are required for the system. The system is locally functional and transmits an individual warning signal to

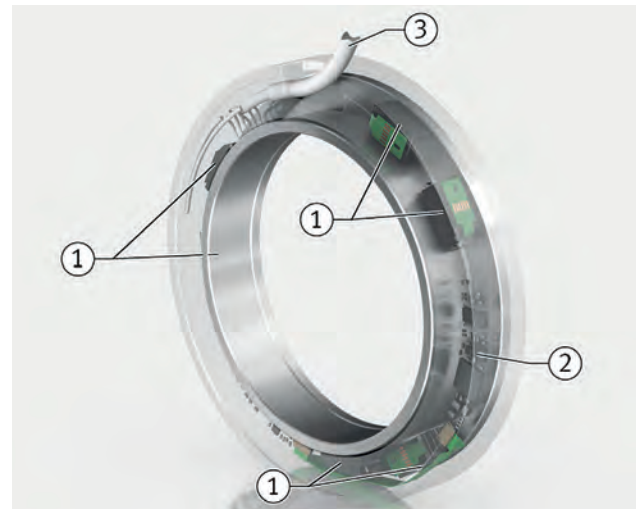

*Figure 1: The spindle bearing monitor system comprises distance sensors (1), an evaluation unit (2), and the cable with CAN connectivity (3) (Source: Schaeffler)*

the machine's control system, which makes the following applications possible:

- ◆ Detecting a crash (collision): The sensor technology is capable of signaling an overload at a digital output within two milliseconds. This allows serious subsequent damage to be minimized or even prevented through fast deactivation of the drive.
- ◆ Long-term protection for machine tool spindles: In practice, continuous mechanical spindle bearing overloads are not immediately identified. In contrast, the monitoring system immediately triggers a warning signal when the overload is parameterized accordingly. The operator can adjust their machining program right after the first manufactured part and reduce the spindle load by using a new tool or modified cutting values, or by employing a more suitable tool type. The operator thus achieves lower and less numerous peak loads, and thus benefits from a longer spindle operating life with fewer machine tool downtimes, which ultimately means more production time and reduced repair costs.

Variant C-A1 outputs the measured radial and axial displacements including tilting via CAN network. Machine tool and spindle manufacturers can use these displacement values to develop analysis tools for optimizing the utilization of spindle capacity, e.g. by visualizing the deflection collective measured by the sensor ring as a load collective. For the first time ever, the machine operator will know the degree to which the spindle capacity in each

## ROTARY ENCODER AND INCLINOMETER



### Ideal for Construction Machinery

Static and Dynamic Inclinometers

High Precision Magnetic Rotary Encoder  
up to 16 Bits

Protection up to IP69K

High Shock and Vibration Resistance

Variety of Interfaces:  
CANopen, J1939, Analog, Modbus

Simple Diagnosis by Means of LED

Additional Versions:  
Safety Compliant and ExProof

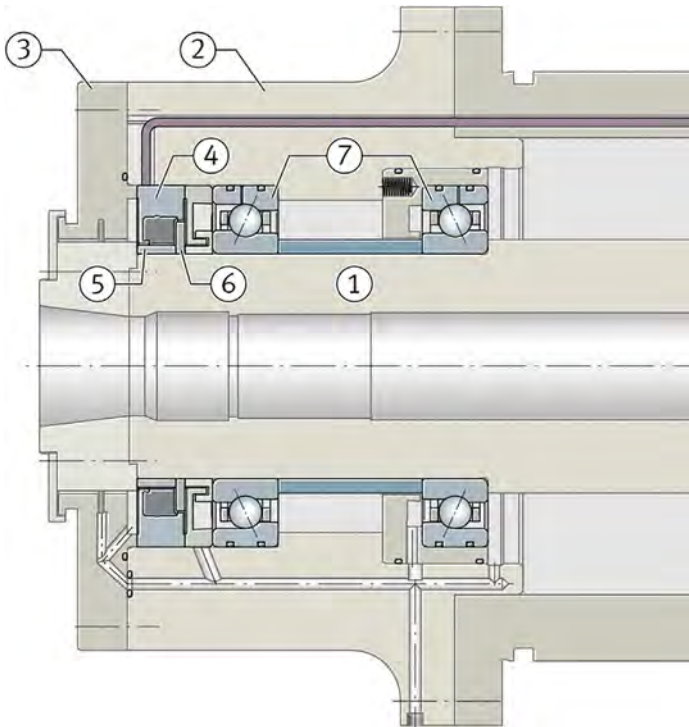

Figure 2: Cross-section of a tool spindle with shaft (1), housing (2), housing cover (3), Spindle-Sense (4), radial (5) and axial (6) measuring ring, as well as spindle bearings(7) (Source: Schaeffler)

machining process is being utilized as a percentage with a high level of accuracy and thus be able to adjust the machining process even more precisely in terms of capacity utilization and operating life for each machine: This means that harmful overloads are prevented despite maximum spindle loads. Safe operation in the limit range allows the operator to increase their productivity and also to benefit from longer spindle operating life and less frequent machine downtimes.

The measured displacements that are outputted via CAN can also be used for zero point compensation. This makes it possible to produce the same quality with larger cutting values or higher quality with unmodified cutting values. The monitoring of the maximum displacement can also be used for quality assurance.

### Electronic versus mechanical overload system

In comparison with mechanical, i.e. passive overload systems, the introduced monitoring system does not just protect the spindle in the event of a collision, it is also a revolutionary system for safely maximizing the utilization of the spindle capacity. For the first time, machine manufacturers can now offer their customers a tool for increasing productivity, machine availability, and quality. ◀



# Smart-bridging CANopen and CANopen FD

This article gives an description on how to smart-bridge classic CANopen and CANopen FD networks.

The CANopen FD protocol has several advantages over classic CANopen: A much more flexible communication model that includes fully-meshed and broadcast communication with Universal Service Data Objects (USDOS), a higher potential bandwidth and larger messages that through the use of CAN FD also offer the extra space needed for authentication, for example with CANcrypt.

However, existing classic CANopen devices cannot be mixed with CANopen FD devices on the same network cable since classic CANopen devices will destroy and generate errors for any CANopen FD communication they detect. So today, when designing new CANopen based networks or adding new functions, features, nodes, or security to an existing CANopen system, you have the following options:

1. Stay entirely in classic CANopen
2. Do a complete transition to CANopen FD
3. Mix classic CANopen and CANopen FD using a smart bridge

## Let's evaluate these options

*Stay entirely in classic CANopen:* For any development you initiate today, no matter if it is something new from scratch or a complete or a partial redesign of an existing system, ask yourself how long the system needs to last and which future enhancements or requirements may come up. Take firmware updates over classic CANopen for example, which are possible but not particularly fast or secure. Security through authentication and encryption during normal operation also could become a requirement, if not today then a few years from now. Would this be possible with only a firmware update?

Our recommendation is to not lock yourself into classic CANopen for new developments. Any new CANopen device you build today should be at least CANopen FD "ready" so that you can easily add enhanced features, faster updates, and security "at any time".

*Do a complete transition to CANopen FD:* This option requires that all devices connected are CAN FD capable. This typically requires new hardware designs

or replacement of off-the-shelf CANopen with CANopen FD components and is only an option if a new system design or a complete redesign of an existing system is started.

You may think that your system will then be "future proof" as all existing and future CANopen FD functions and services are available. However, most devices that currently exist still only speak classic CANopen and you'd be locking yourself out of using any of these for a considerable period of time.

Chances are, you still need an easy migration path from classic CANopen to CANopen FD or vice versa no matter which route you take.

*Mix classic CANopen and CANopen FD using a smart bridge:* This third option allows you do both: a step-by-step transition from classic CANopen to CANopen FD or to add legacy devices and networks to a new CANopen FD design. The idea is that you use two network branches in your system: a classic CANopen branch with those devices without CANopen FD support and a CANopen FD branch with the newer devices that already have it. Making sure that all node IDs are unique, the two are connected as segments of a single virtual network, using a smart bridge as illustrated in Figure 1.

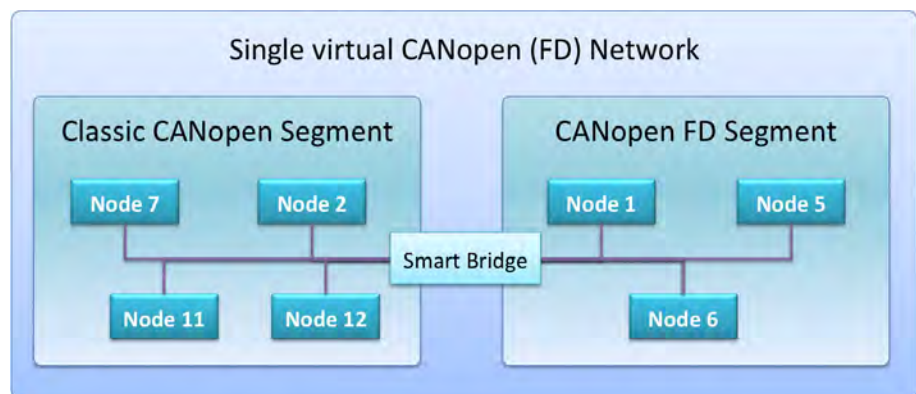

Figure 1: Connecting classic CANopen to CANopen FD using a smart bridge (Source: Emsa)

## How does a smart bridge for classic CANopen and CANopen FD work?

Note that while there is no official standard for this type of bridge yet, we at Embedded Systems Academy saw the need for such a device to ease the transition to the emerging CANopen FD protocol and so came up with its concept. ▶



By monitoring the CANopen (FD) traffic on both sides of the bridge, the bridge learns which node IDs are on which side and where the NMT Master is located. Once the bridge has the complete picture of the network segments, USDO and SDO requests and responses involving a node ID are forwarded if required, based on the position of the sender and receiver.

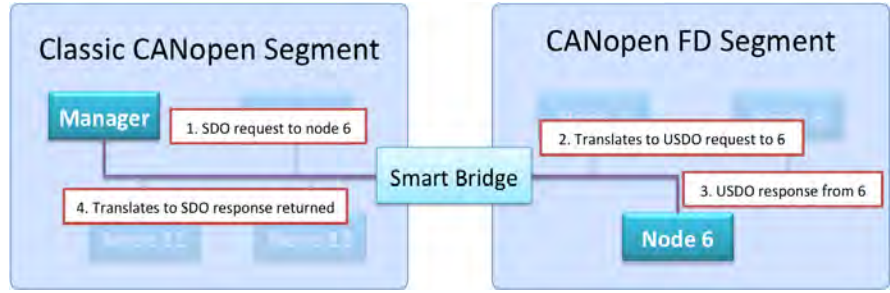

Figure 2: Handling SDO / USDO forwarding (Source: Emsa)

Some messages such as NMT Master messages, bootup messages, Sync messages, and heartbeats are always forwarded to the other segment, as their content is the same in CANopen and CANopen FD. The Emcy (Emergency) messages are forwarded and converted into the respective format.

All default PDOs with a length of eight bytes or less are forwarded as well. An advanced configuration mode allows filtering as well as merging and splitting of PDOs. The “smart” part of the bridge refers to the handling of the (Universal) Service Data Objects - (U)SDO. These are completely transparent for all nodes connected on either side.

If the default SDO client on the classic CANopen side sends an SDO request to a node on the CANopen FD side, the bridge translates it to a USDO request from the bridge itself to the node on the CANopen FD side. The USDO response is received and converted back to an SDO

response on the classic CANopen side. These steps are shown in Figure 2.

If any CANopen FD device sends a USDO request to a node located on the classic CANopen side, the bridge translates this USDO request to a default SDO client request on the classic CANopen side. It waits for the SDO response and translates that back to an USDO response on the CANopen FD side.

Those of you with CANopen (FD) experience will immediately see some challenges and limitations:

1. Potential default SDO client collision on classic CANopen side
2. Segmentation handling of SDO and USDO

In classic CANopen there is only “one set” of SDO client channels available. By default, these belong to the CANopen Manager, so only this device may actively produce SDO requests. Note that there are mechanisms to support additional client channels organized by an SDO ▶

Manager, but due to the complexity involved, this is rarely used.

With the smart bridge, the preferred method is that the classic CANopen side has no device producing SDO client requests. This ensures that the bridge itself can use all default SDO client channels on this side. If another device actively uses the default SDO client channels like a CANopen Manager is present on the classic CANopen side, then CANopen FD devices connected to the bridge must not send USDO client requests to devices on the classic CANopen side of the smart bridge. Future versions of the smart bridge will support SDO Manager-style handling of SDO channels on the classic CANopen side to support more SDO flexibility.

### Segmentation handling of SDO and USDO

If SDO / USDO requests and responses only deal with data transferred that is four bytes or less, the bridging process is relatively simple. One pair of USDO request and response is translated into a single SDO request and response and vice versa.

The handling becomes more challenging with segmentation. On the CANopen FD side, a USDO expedited transfer involving a single USDO request and response message can transfer up to 56 bytes of data.

To convert such a transfer to classic CANopen, we need to use segmented or block SDO transfer. On the CANopen FD side, this also means that USDO requests send to devices in the CANopen segment will be slower, as they translate to multiple messages being exchanged on the classic CANopen side of the bridge. To cope with this situation, the USDO timeout might need to be increased. Figure 3 illustrates the scenario.

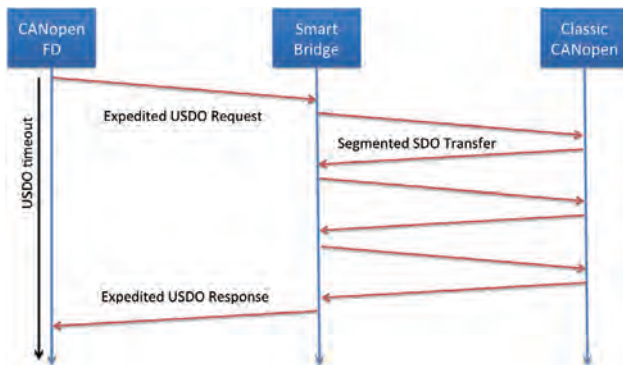

Figure 3: Expedited USDO transfer > 4 bytes translates to segmented SDO transfer (Source: Emsa)

As with all bridging applications involving different performance parameters on each side of the bridge, there will be some limitations with transfers of large data packages like firmware code or configuration tables but we are working on concepts to support these as well.

### Availability of the smart bridge CANopen FD

Our first implementation of the smart bridge is for the PCAN-Router FD from Peak-System Technik and will be available in the upcoming weeks. These devices are based on an ARM Cortex M4F micro-controller from NXP



Figure 4: Peak's PCAN-Router FD as initial hardware for the smart bridge (Source: Emsa)

and offer two CAN (FD) ports. A configuration utility provided will support loading, registration, and configuration of the smart bridge firmware. Versions for other hardware platforms with multiple CAN (FD) ports are available on request. The smart bridge CANopen FD makes a smooth transition from CANopen to CANopen FD technology possible today.

### Authors



Olaf Pfeiffer, Christian Keydel  
Emsa (Embedded Systems Academy)  
[info@esacademy.com](mailto:info@esacademy.com)  
[www.esacademy.de](http://www.esacademy.de)



# COMPLETE MINING TRUCK CONTROL SOLUTIONS.

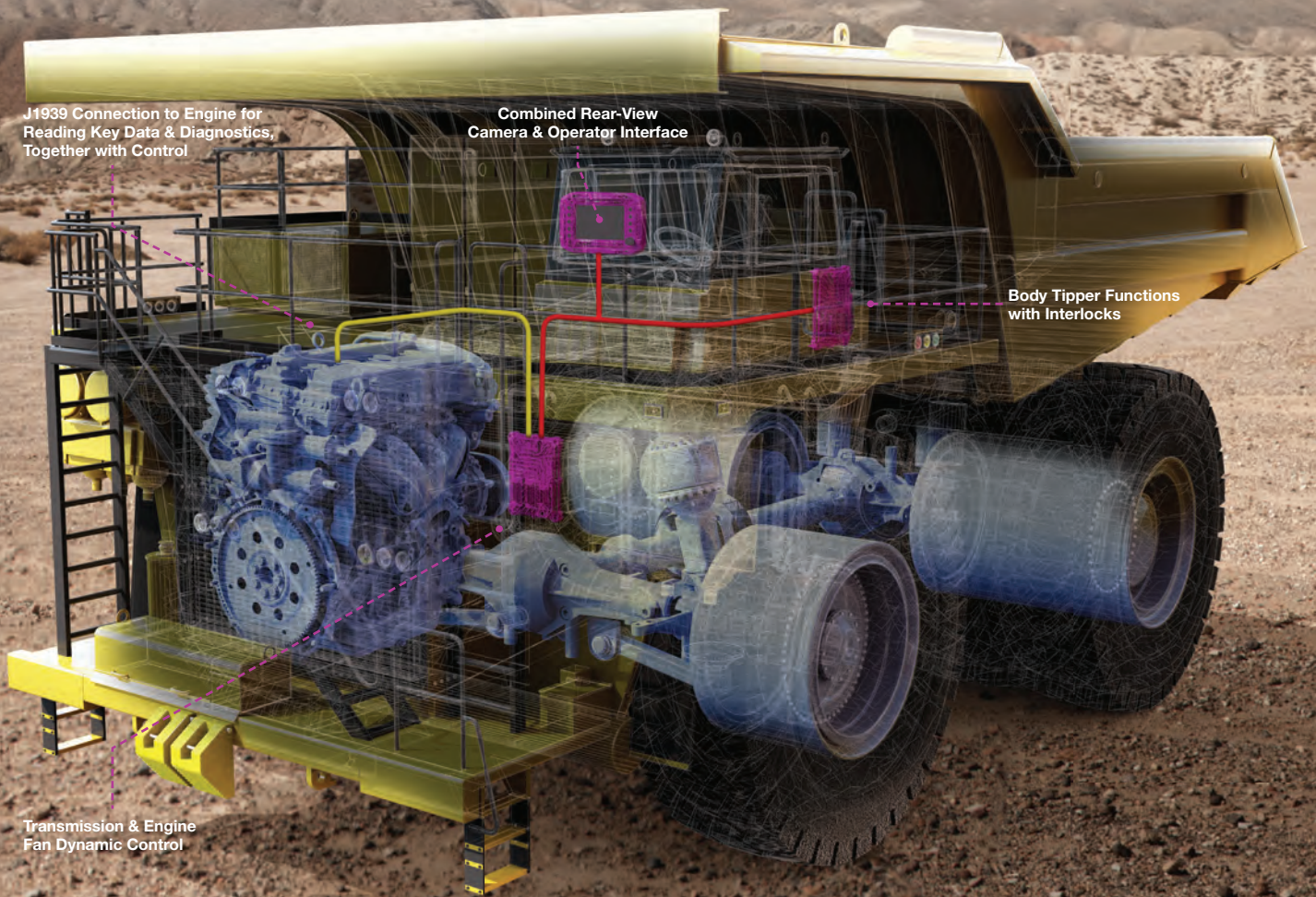

**DSEM240**  
CAN Slave  
Module (44 I/O)



**DSEM640**  
Programmable  
Controller (68 I/O)



**DSEM643**  
Programmable  
Controller (34 I/O)



**DSEM840**  
4.3" Programmable  
Display



**DSEM870**  
7" Programmable  
Display



## DSEControl® M-Series

DSE has been delivering world-class control solutions to its customers for over 40-years. During this time the company has developed a reputation across the globe for its UK engineering and manufacturing excellence.

The **DSE M-Series** builds on this reputation. The innovative collection of programmable controllers & displays and CAN slave modules provide customers with complete mining truck control solutions.

To learn more about **DSE M-Series** products, visit [www.deepseaelectronics.com](http://www.deepseaelectronics.com)

### DEEP SEA ELECTRONICS LTD

Highfield House, Hunmanby Industrial Estate Hunmanby, North Yorkshire, YO14 0PH, UK

**TELEPHONE:** +44 (0) 1723 890099



# CANopen motors in automated guided vehicles

Serving as the heart of locomotion for mobile robots are integrated motors, used for steering and powering the main drive motors. These motors feature CANopen.

In smart factories, mobile robots are freeing humans from performing logistic and other tasks such as moving materials from one warehouse to another. Autonomous mobile robots (AMR) and automated guided vehicles (AGV) are the two main classifications of mobile robots on the market. Serving as the heart of locomotion for these robots are integrated motors used for steering and powering the main drive motors.

While brushed DC and AC induction motors are frequently incorporated into robots due to cost, brushless servo motors offer greater torque density, efficiency, speed regulation, life, and smoothness in motion. A variation of a brushless servo motor, the integrated servo motor offers additional benefits. Combining a servo motor and controller into one package, the integrated servo motor saves on space, wiring, and costs over conventional systems with separate motor and drive components (Figure 1). Using integrated motors, robot designers can focus less on control placement and wiring and more on non-motor system components for faster design iterations. By reducing the number of components in the system, integrated motors simplify the bill of materials, enable faster design cycles, and save money.

## Integrated motors in a CANopen control network

The onboard controller of the integrated servo motor can provide the same control interface options as a separate controller, including CANopen networking (Figure 2).

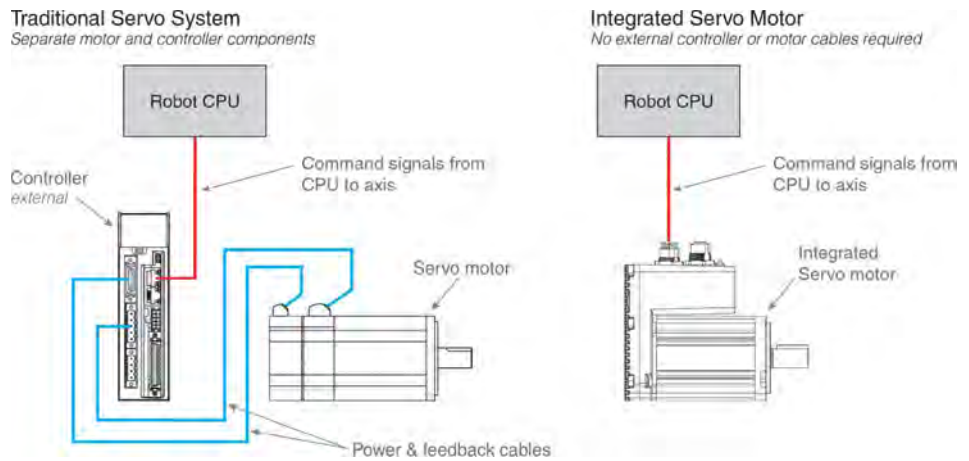

Figure 1: An integrated servo motor eliminates the need for an external motor controller as well as motor power and feedback cables, freeing space in the robot to accommodate other material handling mechanisms, sensors or operator-interface devices (Source: Applied Motion Products)

In one AGV application, dual MDX integrated servo motors (Figure 3) from Applied Motion Products are controlled on an electrically-isolated CAN network. The electrical isolation provides a key benefit in AGV systems where a solid, reliable grounding point may not be possible for all nodes. An embedded Linux module running a CiA 301 CANopen host sends real-time CiA 402 profile velocity commands to the individual drive wheels. An integrated watchdog monitors the communications channel and ensures the

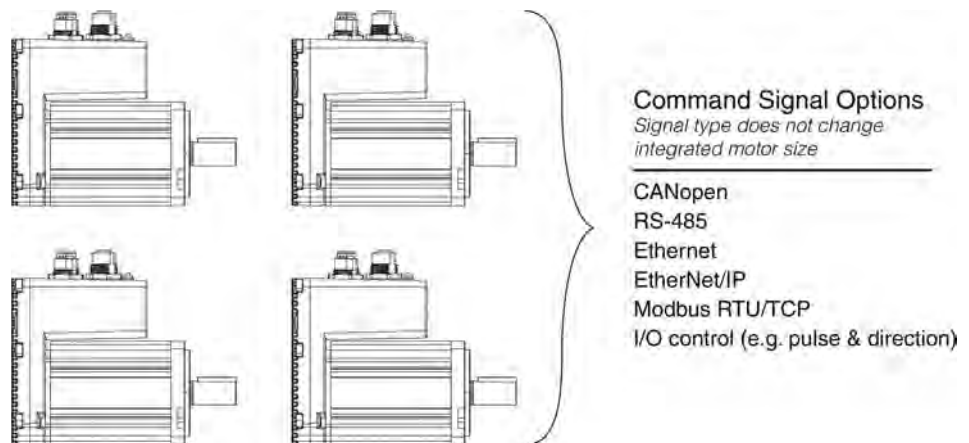

Figure 2: Integrated servo motors provide the same control interfaces as separate servo drives, including CANopen and other industrial communication protocols (Source: Applied Motion Products)





Figure 3: Photo of an MDX integrated servo motor where control electronics are housed at the back of the motor, near the feedback device. No other external electronics package is required to drive or control the motor. The motor includes connectors for power, communications, and I/O. Its on-board controller utilizes the same command interfaces as external motor controllers including CANopen.

servo motors can run stored programs that incorporate commands for various kinds of motion, I/O control, and machine sequencing, as well as math functions that enable users to create complex motion profiles and control algorithms. MDX motors feature two environmental rating options, IP65 and IP20. The most popular IP65 rated motor includes M12 connectors for all connection points. IP20 rated motors feature pluggable connectors that save cost in high volume, price-sensitive applications. ◀

vehicle stops safely if the host encounters a communication problem.

In addition to simple velocity commands, the use of the CANopen network allows the host to monitor important drive conditions such as temperature, drive status, and the actual current being delivered to the motors, all without the use of additional wiring or sensors. Along with the two drive wheels, a J series servo motor from Applied Motion is used with a DC-powered SV200 servo drive to power the lift axis of the AGV. The lift axis runs in a CiA 402 profile position mode to move to one of several pre-determined locations depending on the task.

In addition to acting as CANopen slave devices, MDX integrated

## All you CAN plug

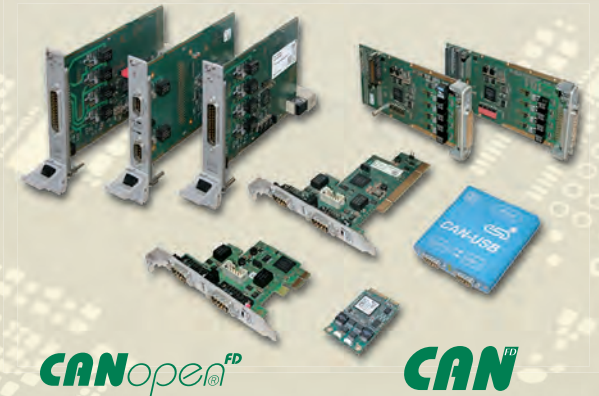

### CAN / CAN FD Interfaces

#### Product Line 402 with Highspeed FPGA

- Various Form Factors**  
 PCI, PCI Express® Mini, PCI Express®, CompactPCI®, CompactPCI® serial, XMC and PMC, USB, etc.
- Highspeed FPGA Design**  
 esdACC: most modern FPGA CAN-Controller for up to 4 channels with DMA
- Protocol Stacks**  
 CANopen®, J1939 and ARINC 825
- Software Driver Support**  
 Windows®, Linux®, optional Realtime OS: QNX®, RTX, VxWorks®, etc.

sps

smart production solutions

Nov., 26. - 28., 2019  
hall 5, booth 131

#### esd electronics gmbh

Vahrenwalder Straße 207 | D-30165 Hannover  
Tel.: +49(0)511 372 98-0  
info@esd.eu | www.esd.eu

Quality Products -  
Made in Germany

#### esd electronics, Inc.

70 Federal Street - Suite #2  
Greenfield, MA 01301  
Phone: 413-772-3170  
www.esd-electronics.us



www.esd.eu

#### Author



Eric Rice  
Applied Motion Products  
[info@applied-motion.com](mailto:info@applied-motion.com)  
[www.applied-motion.com](http://www.applied-motion.com)

# "The data processing moves into the edge"

Should IoT be integrated directly into the device, into a machine part, or directly into the sensors and actuators? SYS TEC Electronic answered these questions in an interview.

IoT (Internet of Things) pursues the approach of using new technologies and communication concepts to make data available in a cloud, connect it, and to generate further benefits from this aggregated data. The most common methods here are data transmission via MQTT or the connection of data to the cloud via OPC UA. Current developments go one step further and regard edge computing as a way of automating and interconnect processes at the point of action, i.e. where data is generated - in industrial production environments, directly at the machine.

With which methods is it worth going one step further? Should IoT be integrated directly into the device, into a machine part, or directly into the sensors and actuators? Dr. Frank Jungandreas, Senior Engineer at SYS TEC Electronic and Nadine Mensdorf, Product Manager at SYS TEC Electronic answer these questions.

**Q:** How do you classify CANopen? What does SYS TEC Electronic connect with CANopen?

**Nadine Mensdorf:** CANopen has long since established itself as a replacement for proprietary backplane buses within devices. CANopen can be found on the market in special-purpose machines, in battery management systems, commercial vehicles, in the lift sector, and in the mobility sector. It combines sensors and actuators in one machine and transmits status values, process data, or triggers other actions. Just as CAN is used in the automotive industry, CANopen is used for special vehicle superstructures such as fire trucks, cranes, or agricultural machinery.

Ourselves as well as our customers have adapted the SYS TEC Electronic CANopen stack over many years for various controllers and terminal devices in various applications. Numerous customized developments and manufactured products contain our solution. We also use CANopen for current inquiries, projects, and customer solutions.

Our product portfolio includes our CANopen chip, the Sysworxx I/O modules based on it, and our industrial controllers. We offer terminal devices for use on the DIN rail, embedded control units, as well as customized individual solutions.

In addition to many other protocols, our CANopen implementation is used on all our IoT controllers with IEC 61131-3 PLC programming system for communication on the field level. This also applies to our edge controller Sysworxx CTR-700 as well as our single chip IoT controller Sysworxx CTR-100.



Figure 1: The edge controller Sysworxx CTR-700 uses the CANopen implementation for communication in the field level (Source: SYS TEC Electronic)

**Q:** CANopen and IoT - how does it fit together?

**Dr. Frank Jungandreas:** The IoT idea is often initially explained by connecting data with the cloud and the connection of devices to the cloud through protocols such as MQTT or OPC UA. But how do you effectively get cleansed, pre-processed data that is relevant for evaluation? If you look at a system as a whole, data can often be pushed directly to the cloud via its controller. This brings us to edge computing, i.e. decentralized data acquisition and processing, combined with gateway functionality, which serves as an interface to higher-level systems.

With this in mind, viewing a machine in the capital goods sector as a self-contained object is a very high-level approach. Internally, its functionality combines several executing and monitoring devices, sensors and actuators. The intelligence for the Internet of Things should start where the "things" are located - i.e. exactly where data is generated: within the industrial production processes, i.e. directly in the machine.

If we look at the "things" in detail as individual devices with a dedicated functionality, we have to begin to provide each object in the system with intelligence and link them together. Ethernet-based technologies clearly predominate on the level for connecting individual devices in industrial production environments. In contrast, this technology is rarely used within a machine on the fieldbus level. The reasons why it often makes more sense to rely on CANopen within a machine than to use IP-based technologies are manifold. On the one hand, the vast majority of micro-controllers used today in machine control systems already have one or more CAN interfaces integrated. The transmission of data via CAN requires significantly less energy than Ethernet-based systems, and there are numerous



cost-effective tools on the market for commissioning and troubleshooting.

The automotive industry is a good example of how powerful CAN is. Within the vehicles, CAN is used to communicate the status of various components, transmit process data, and trigger actions. At the same time, CAN provides the external service interface, which can be used to read out error information and telemetry data.

CANopen offers just as many advantages in the field of automation for use within a machine. Lean, energy-efficient communication units can be quickly implemented with inexpensively available hardware.

**Q:** CANopen therefore migrates directly into the machines. Please explain this more in detail.

*Dr. Frank Jungandreas:* Exactly, many machines and devices use CANopen as internal machine bus, without this being visible from the outside. CANopen is much leaner, smaller, and at the same time more cost-effective than comparable IP-based communication. In addition, the power dissipation is also significantly lower than for example with Ethernet.

This makes CANopen ideal for autonomous, e.g. battery-powered devices. The number of applications in this area will increase considerably in the coming years.

A further field of application for CANopen is condition monitoring and predictive maintenance, i.e. the constant monitoring of device data in order to detect possible failures at an early stage and to maintain them proactively. Due to the integrated CAN interfaces, the simple wiring and low power and computing requirements, CANopen can be integrated at any place in a machine with little effort.

On this basis, our customers can implement intelligent "things" quickly and inexpensively. The necessary investment of time and money remains manageable and the technological risk is low. Established support tools are also available, for example for diagnosis or configuration.

**Q:** What does a typical use case for this scenario look like?

*Nadine Mensdorf:* Within a plant or machine there are several devices which have to be synchronized with each other. The individual actuators are interdependent. To ensure successful cooperation, the devices have to be able to exchange information about their process values such as availability, power consumption, and maintenance data.

In the field of energy management, for example, current peaks can be distributed in a way that large consumers are only switched on consecutively instead of simultaneously, thus significantly reducing the current load on the system.

CANopen connects sensors and actuators purposefully, it transmits status values, process data, and triggers actions. There must be no detached communication unit. Rather, it should be integrated directly into the intelligent sensors and actuators.

Is a sensor ready for operation, overheated, or dirty? Which process is influenced by the availability of the sensor? Can another sensor take over the task or have the process values of the overall system, such as speed, etc., to be adjusted in this case? ▶



## YOUR LINK TO THE WORLD OF MODERN AUTOMATION - X90

[www.br-automation.com/mobile-automation/](http://www.br-automation.com/mobile-automation/)

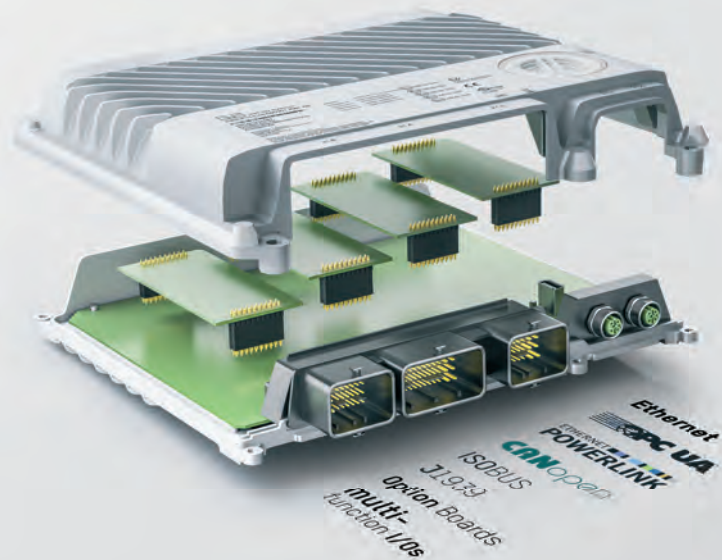

- Scalable hardware platform
- Preprogrammed software components
- 3-times faster development

PERFECTION IN AUTOMATION  
A MEMBER OF THE ABB GROUP



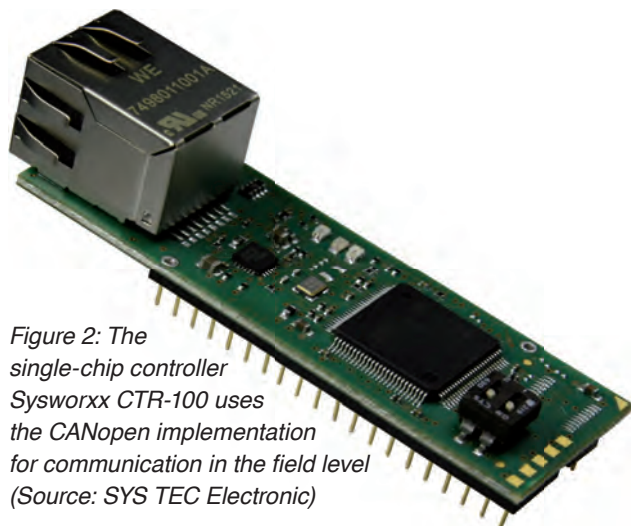

Figure 2: The single-chip controller Sysworxx CTR-100 uses the CANopen implementation for communication in the field level (Source: SYS TEC Electronic)

Such intelligent assemblies are a must-have for new machines and systems, as they form the basis for concepts such as predictive maintenance. A visible trend in the manufacturing industry is retrofitting, the upgrading of existing facilities with intelligent assemblies. For machine manufacturers, this opens up new fields of business, and for end users, it increases investment security - even for existing systems.

Machine manufacturers in the field of special-purpose machine construction, who currently see themselves as late adopters, are beginning to integrate intelligent assemblies into their machine concepts. Sensor and actuator manufacturers design the intelligence directly into their devices, which in turn serve as supplements for existing systems.

**Q:** Do you see increasing numbers of retrofit solutions on the market in the coming years?

**Nadine Mensdorf:** Certainly. The greater the investment in machinery, the longer it will typically be used. In these areas, the need for additional intelligence will grow.

Such a retrofit solution has to be always considered in its entirety. Let us remember the key data and advantages of CANopen. Intelligent, CANopen-capable devices can be developed within a short time at low hardware costs. The components have a high technological maturity and thus entail a low technological risk - but also a high potential to generate new lines of business.

Increasing performance and cost pressure demand fast reaction as well as proactive instead of reactionary maintenance to generate savings. Innovative technologies are not used for their own sake, but to increase efficiency. The focus here is on uncovering hidden costs. If these can be made visible, it is possible to eliminate the issues associated with these costs.

How easily an intelligent CANopen device can be implemented can be demonstrated in just a few steps. Let's take our CANopen chip as the first example. This plug-in module can read and write analog and digital values in seven available I/O configurations. The device profile for CANopen I/O devices and the CANopen communication profile, i.e. the semantics of the unit, are components of the CANopen chip firmware. By integrating the CANopen chip into a controller, it can already communicate its process data semantically defined.

In a second example, let's start with our single chip controller, the Sysworxx CTR-100. In an intelligent machine environment, we only need a simple I/O interface and the CAN transceiver for communication. The Sysworxx CTR-100 chip already contains all the intelligence required to read process data via CANopen, process it locally and pass it on to a cloud via MQTT.

Integrated into a sensor, it provides the capabilities for self-diagnosis - it can process self-generated values and data as well as environmental data, control them via CANopen, control functionally adjacent units, but also push pre-processed values via MQTT to a higher-level edge controller.

The data processing moves more and more into the edge, i.e. directly into the machine on the shop floor - and of course into the "things". Only through targeted networking of the individual "things" useful data can be generated. A cloud alone is not enough - the application only becomes a business model when it is fed with corresponding data which is interconnected.

The Sysworxx CTR-700 edge controller allows data to be recorded directly from the field level via CANopen and preprocessed locally. This information can then be forwarded via MQTT or OPC UA and transferred directly to a cloud. Of course, other systems can also be connected, such as process control systems, which record, analyze, and visualize the machine data in an appealing way. The data records directly from the machine can be supplemented with additional information. For example, with environmental data to generate an image of the overall situation of a plant. This makes it possible to monitor and control entire plant systems very efficiently. ◀



#### Contact

Nadine Mensdorf  
SYS TEC Electronic  
[nadine.mensdorf@systec-electronic.com](mailto:nadine.mensdorf@systec-electronic.com)  
[www.systec-electronic.com](http://www.systec-electronic.com)



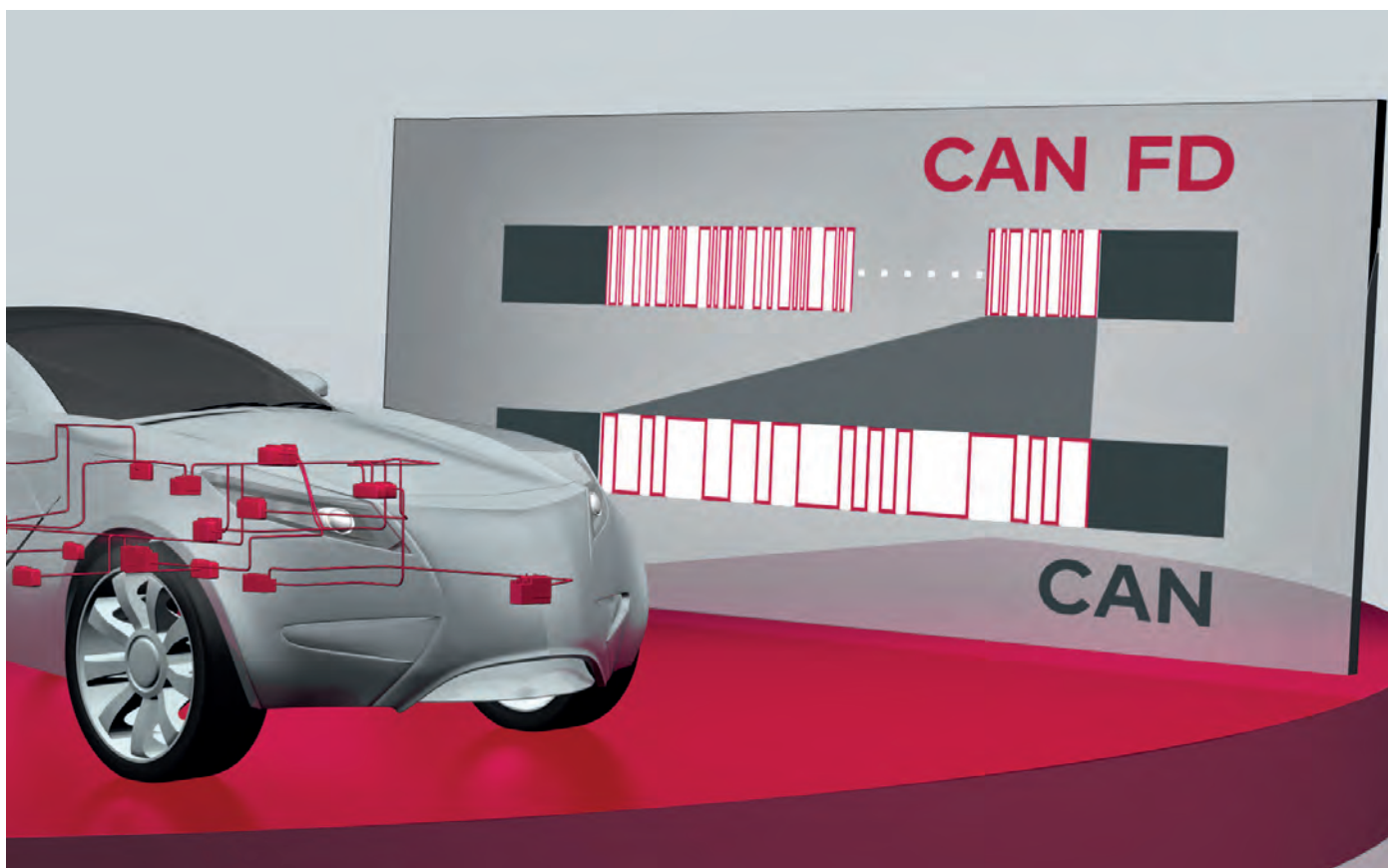

## First Class Solutions for Your CAN (FD) Projects

### Your Universal Tool Chain

**Increase efficiency of your projects with the universal tool chain from Vector:**

- > High-professional tools for testing, flashing and calibrating ECUs
  - > Flexible network interfaces
  - > New all-in-one network disturbance interface
  - > Powerful logging solutions for test fleet operators
  - > High performance oscilloscope
  - > Proven design tools for network architectures
  - > Easy to configure AUTOSAR basic software
  - > Worldwide engineering services and trainings
- More information: [www.can-solutions.com](http://www.can-solutions.com)

**More CAN power by Vector: benefit from 30 years of networking experience.**

# Ethernet links CANopen domain controllers

Structuring the vehicle network architecture into separate domains becomes highly meaningful. A powerful unit can be used to perform all domain-related tasks.

The agricultural machinery market is advancing as fast as many other high-tech sectors, and we see more and more start-ups and large companies moving into the market.

Major trends such as connectivity and automation, as well as the growing ecosystem of software and hardware that needs to coexist and interoperate, bring new challenges that must be addressed in the very first stages of the development of a mobile machinery – right at the drawing board. Above all, a machine will no longer be an independent entity, but will likely exist as part of a group of machines that form a higher entity.

All of these trends and technologies bring about three direct consequences for the electronic architecture of a vehicle:

- ◆ Higher bandwidth requirements are imposed on the vehicle's communication channels.
- ◆ The machine's electronics are becoming increasingly complex.
- ◆ Security must be improved.

## Bandwidth requirements

In general, and across all verticals of mobile machinery markets, there is an increase in the amount of data being transmitted. Newer, more complex sensors and cameras produce more data that needs to be processed by the control units and displays. Furthermore, the connectivity between different control units in different areas of the machine requires reliable data distribution over the electronic network.

Modern agricultural machines, such as tractors or highly automated harvesters, employ numerous CAN networks to enable communication within the control system, for example engine CAN or vehicle CAN.

For this purpose – depending on the application – the CAN-based Isobus (ISO 11783) is used in addition to allow communication with implements such as trailers. SAE J1939 is often used as a basic protocol for these CAN networks, which specifies a bit rate of 250 kbit/s. In the case of Isobus, an implement that offers virtual terminal client functionality must transmit the associated object pool

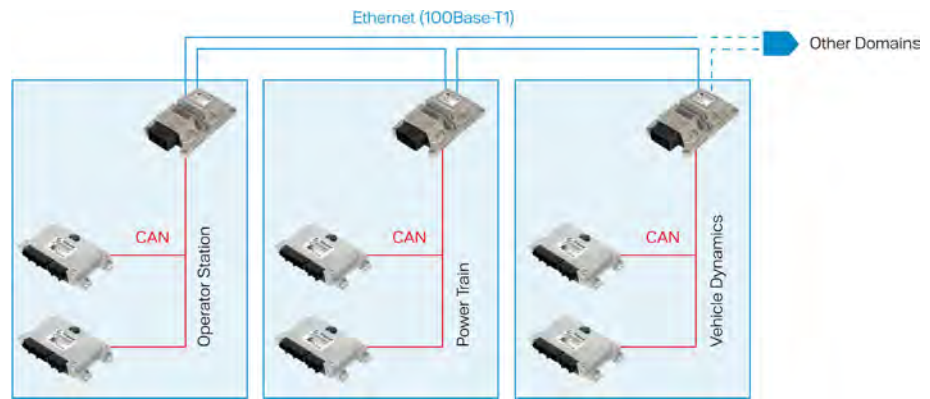

Figure 1: Domains separated by Ethernet interfaces using a ring topology (Source: TTCControl)

to the Isobus universal terminal in the machine. Depending on the specific features and functionality of the implement, this object pool can take up to a few megabytes. At 250 kbit/s the transfer of data that occurs at start-up can take a significant amount of time, especially considering protocol overheads and the fact that the communication protocol is contention based and that the CAN network must be shared with other devices.

The bandwidth requirements of new technologies, such as the continuously increasing resolution of displays, IP cameras (in some cases with surround view functionality), sophisticated fleet management systems using technologies from the IoT/Industry 4.0 world, as well as increasing automation of machine functions all exceed the currently available bandwidth by orders of magnitude. A single IP camera creates a data throughput in the range of 10 Mbit/s. A modern CAN-based system which includes complex gateways often has an overall bandwidth of approximately 1 Mbit/s to 2 Mbit/s, whilst future technologies will create a data volume that is up to three orders of magnitude higher than currently available.

Several of these functions, especially the automation functions in the area of drive, steering, and working functions also set strict requirements on functional safety, security, and real-time capability. These requirements come to the fore when automation functions have to share the physical communication medium with other services, for example in a steer-by-wire system that shares a network with the diagnosis system that has cloud access. In this case, it must be ensured that in the event of problems in the diagnosis system, the automation function continues to have guaranteed bandwidth and latencies, so that the steering continues to work reliably and safely, despite any unwanted network load created by the diagnosis system. ▷



At this point the need for different paths and routes for data arises in order to transverse vehicles without compromising intended functionalities of each particular block. This can be achieved by utilizing alternative transport technologies which operate side by side to create multiple network domains within the same architecture. Traditional control protocols can be implemented using CAN-based protocols, whereas bandwidth intensive applications and components can utilize the added capacity of Ethernet technology. Data then flows from one interface to the other as needed by the application. At the intersection of the different interfaces a central communication node ensures that the data is properly and efficiently transmitted from source to destination. This communication node, or gateway, allows for the separation of different “zones” and enables the implementation of very complex systems using a segmented and scalable approach.

It is worth noting that in the automotive market, which has very similar requirements to the agricultural market, the use of Ethernet is now pervasive, and standards based. Suppliers of Automotive Ethernet (100Base-T1, 1000Base-T1) Socs are now in full production and the adoption rate is increasing. Adoption of the technology in the mobile machine market is slower but will grow in the coming years as the applications demand it. Standard Ethernet (100Base-TX, 1000Base-TX) is also present in many devices in the off-highway market, such as displays or telematics nodes, as it provides a way to connect to the machine with service computers and diagnostics tools.

Many industry players are already working on solutions to address the increasing needs of bandwidth and capacity of machine architectures. Most notably the AEF and the group of companies that contribute to the Isobus standard have been working on the High Speed Isobus standard, which provides gigabit grade connections over unshielded twisted pairs and is based on existing Ethernet technology.

## Increase in complexity

New demands for advanced features are increasing the complexity of the electrical network within the vehicles, becoming a burden on the traditional levels of bandwidth and computing power. Until very recently, electronic control units were used almost exclusively for the control of electrohydraulic systems, such as valves, actuators, etc. The code needed to implement said functionality was often simple enough to run on low-cost MCUs (micro-control unit). Today, controllers are morphing into sophisticated platforms with high computational power that not only control other elements in the vehicle but also process enormous amounts of data at very high speeds. Increase of performance no longer translates into an increase in the number of electronic units needed. The exponential increase of system complexity can only be met with very powerful electronic control units, with high performing CPUs (central processing unit), often with multiple cores running in parallel, and external interfaces to match.

As complexity increases, a domain-based architecture may prove useful in keeping complexity levels manageable and provides a more modular approach to ▷



USB-to-CAN FD  
for CAN and CAN FD

## PC/CAN Interfaces

Easy CAN and CAN FD connection for your application

- Interface for your control or monitoring application as well as for the Ixxat tool suite
- All PC interface standards supported with one uniform driver interface – easy exchange without programming!
- Drivers (32/64 bit) for Windows7/8/10, Linux, QNX, INtime, VxWorks and RTX
- APIs for CANopen and SAE J1939



Discover more:  
[www.all4CAN.com](http://www.all4CAN.com)



CAN-IB 200/600/PCIe  
1-4 x CAN,  
CAN FD



CAN@net NT 420  
Ethernet PC Interface,  
Bridge, Gateway  
4 x CAN, 2 x CAN FD



CAN-IB 120/520/PCIe  
Mini 1-2 x CAN,  
CAN FD



CAN-IB 230/630/PCIe 104  
2-4 x CAN, CAN FD



CANblue II - Bluetooth  
PC Interface, Bridge,  
Gateway  
1 x CAN

HMS Industrial Networks GmbH

Emmy-Noether-Str. 17 · 76131 Karlsruhe

+49 721 989777-000 · [info@hms-networks.de](mailto:info@hms-networks.de)

[www.anybus.com](http://www.anybus.com) · [www.ixxat.com](http://www.ixxat.com) · [www.ewon.biz](http://www.ewon.biz)



software development. Moreover, significant amounts of data can be kept within the domain itself, avoiding an overload of the existing networks. Only data that needs to be shared by the different domains would cross a communication gateway.

The different domains could be connected using Ethernet technology if available on the domain controller unit, so that the CAN networks are not overloaded and remain reserved for the control applications. This segmenting into different domains might not be suitable for smaller machines that only require a very low number of control functions but as we connect machines to the cloud and to other vehicles in the field, even rather simple devices begin to need some concept of domains.

Figure 1 depicts an example of a machine with several domains separated by (automotive) Ethernet interfaces using a ring topology.

### Need for improving security

Security will likely become one of the most, if not the most important topic in future designs of machines. As most machines today include both wired and wireless ports to connect to the outside world, it is already of the utmost importance to implement some type of security mechanism for diagnostics ports, cloud platforms, or construction, and farm site infrastructures. Connectivity to cloud platforms for machine monitoring or farm management software products are now almost a firm requirement among all players, as unprecedented demands of efficiency in the field require detailed analysis of processes and parameters related to the farm. These wireless interfaces are not the only potential point of entry for attackers; diagnostic or maintenance ports could also be used for entry to the electrical network of the machine. In essence, any physical port could be used for malicious or fraudulent purposes – the potential for such susceptibility only continues to increase.

Smart farming and its associated technologies offer farmers the potential for reaping huge benefits by reducing cost and increasing crop yield, however it can also pose a threat to farmers and even machine manufacturers. Hackers could target the farming sector for any number of reasons, as we have seen in some other industries in the past. Potential threats could be ransom-demands for blocked machines, but also a breach of data collected by the farmer which could potentially provide significant value to criminal organizations. Machine manufacturers may also be at risk of losing money to tech-savvy owners who hack their machines in order to tweak performance levels or manipulate machine data for fraudulent purposes.

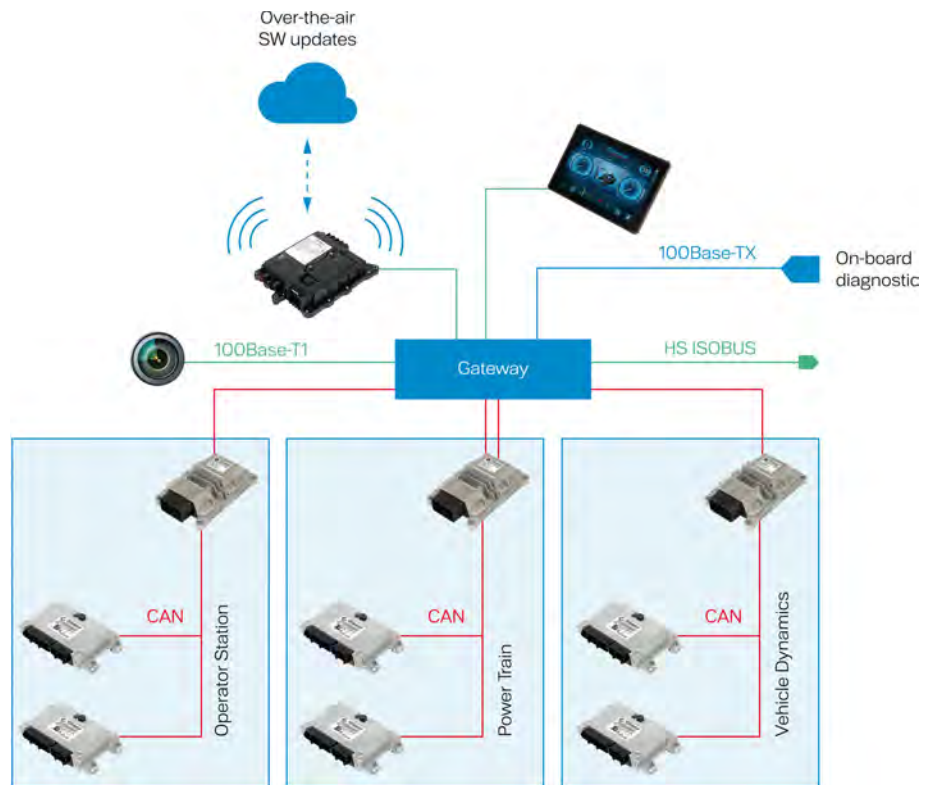

Figure 2: Illustration of vehicle architecture with a central communication node (Source: TTCControl)

As we transition to higher levels of autonomy in the field, security becomes increasingly important, as machines will independently make decisions that could affect yield performance or even human life. If a machine is to operate on its own or be able to detect and react to obstacles, including humans, it is of the utmost importance that the machine and its associated functionalities have not been tampered with.

It is therefore a hard requirement on machines to have a strong security concept that ensures that any kind of attack or unwanted modification can be avoided. Such a security concept is implemented at machine level. It not only affects telematics units or diagnostics ports, but rather it should provide an end-to-end concept that safeguards each of the key elements of the machine. To this end, a specific unit is required within the vehicle that is in charge of “policing” data traffic coming in and out of the machine, and within the machine itself. This gateway should be involved in security sensitive procedures, such as firmware updates (over-the-air or local), diagnostics, and M2M communications for machine control.

For example, the gateway could provide (amongst other measures) isolation between an “outside network” based on wireless connectivity and Ethernet and the “in vehicle network” based on CAN and potentially also Ethernet. Telematics, diagnostics, and a WLAN connection could be connected to the gateway, and not directly to the devices on the CAN networks, such as the ECUs.

A firmware update process triggered from the telematics unit (OTA FW update) or from the diagnostics port would then be authenticated by the security gateway before being executed. Encrypted communication could be enforced between the gateway and an outside device (PC, diagnostics device, etc.) by using protocols such as TLS in order to prevent “man in the middle” attacks or other unauthorized access attempts. Furthermore, TLS could be ▶



used between the gateway and the ECUs connected to it to increase the level of security of the whole vehicle.

A secure boot mechanism could then be implemented where a check of the firmware images loaded in each of the control units would ensure that the machine is safe to operate. Any anomaly in the machine software could be detected and appropriate actions executed.

Another vehicle architecture is shown in Figure 2 in which a central communications node, or gateway is utilized. This device provides data routing through the different domains and interfaces (CAN to CAN, CAN to Ethernet, Ethernet to Ethernet, HS-Isobus to display and/or cloud, and so forth), as well as security mechanisms to avoid fraudulent use or malicious attacks.

Future and even present developments in the agricultural sector only highlight and reinforce the importance of the three aforementioned consequences regarding vehicle architectures (increase of complexity, bandwidth requirements and necessary security efforts). For instance, the “Tractor Implement Management” (TIM) being implemented as an Isobus functionality will allow the implement to automate some operations of the tractor. Implements from various manufacturers will work together with tractors from several different providers. At the same time the tractor and the implement will also receive commands from other vehicles in the field and even real-time command and analytics information from cloud platforms. This combination of wired and wireless automation will require a very high degree of security and performance in order to ensure safe operations.

New devices, like the ones offered by TTControl, will be integrated in the vehicle architecture as centralized communications and control nodes or high-performance computing platforms. Displays will also experience significant increases in performance and complexity as operator assistance functionalities are integrated. New powerful CPUs with support for multiple cores operating in parallel, as well as real-time operating systems are key in addressing these new trends. Functional safety of the systems will also pose a major challenge in the new era of automation and digitalization of machines, especially if some machines are also to share the road with vehicles that are not part of the farm. This vision is being realized today – the introduction of new, scalable, and flexible architectures will play a critical role for the development speed of the farms of the future. ◀

## Author



Jose Ogara  
TTControl  
[products@ttcontrol.com](mailto:products@ttcontrol.com)  
[www.ttcontrol.com](http://www.ttcontrol.com)



**CAN@net NT**  
CAN-to-Ethernet Gateway/Bridge  
with 4 x CAN and 2 x CAN FD

CAN and CAN FD

# Repeater, Bridges and Gateways

- Save costs due to simple wiring
- Increase your system reliability and protect devices by galvanic isolation (up to 4 kV)
- Filter/conversion functionality as well as coupling of CAN and CAN FD
- Bridging of large distances and easy system access via Bluetooth or Ethernet
- **NEW:** Cloud connection via MQTT and easy execution of tasks using “Action Rules” – no programming!



Discover more:  
[www.all4CAN.com](http://www.all4CAN.com)



# From "maker" PC to industrial computer

*Can the Raspberry Pi, known as a hobbyist PC and widely used as an experimental platform, really score points with its cheap image compared to high-quality standard industrial PCs?*

With an Raspberry Pi starter kit, Kontron is laying the cornerstone for industrial and commercial use of the Raspberry Pi platform in companies and organizations.

The requirements in industrial use in terms of performance, reliability, and long-term availability are many times higher than those of university labs or hobby rooms.

According to the experience of Kontron Electronics (formerly Exceet Electronics from Ebbs in Austria and now part of the Kontron and S&T), the rise of the Raspberry Pi is indeed unstoppable. This has less to do with the fact that it is technologically unique, but rather with the fact that it is well known and proven among professional newcomers.

In this, it is comparable to Microsoft Office or Adobe products: Inexpensive entry-level products are by their very nature popular in schools and universities for teaching purposes. Later, when pursuing a career, this experience makes it expedient for companies from a training perspective. Thus, they reluctantly settle for the unfamiliar commercial software.

This is also the experience Kontron Electronics has had for about five years: designs supplied by customers are increasingly based on Raspberry Pi prototypes. Customer side engineers and developers have been trained on this platform, which gets them results on low-cost platforms such as Raspberry Pi, Arduino, or Beagle Board quickly, with Raspberry Pi accounting for the lion's share. Kontron Electronics itself is not entirely innocent in this development, as Raspberry Pi is often used for bachelor's and master's theses supported by the company.

## Customer side users and developers demand Raspberry

Kontron Electronics has many years of experience in selecting the right embedded platform for customer requirements and bringing an existing design draft to series production. This often means that complete designs based on Raspberry Pi needed to be developed from scratch in terms of hardware and software in order to obtain an industrial processor and board platform for series production. The financial and time expenditure for customers was correspondingly high, the product's time-to-market – from first draft to a production-ready platform – correspondingly long. For Kontron Electronics, this was reason enough to commit itself to establishing Raspberry Pi as an alternative – or rather as a supplement – to standard industrial platforms.

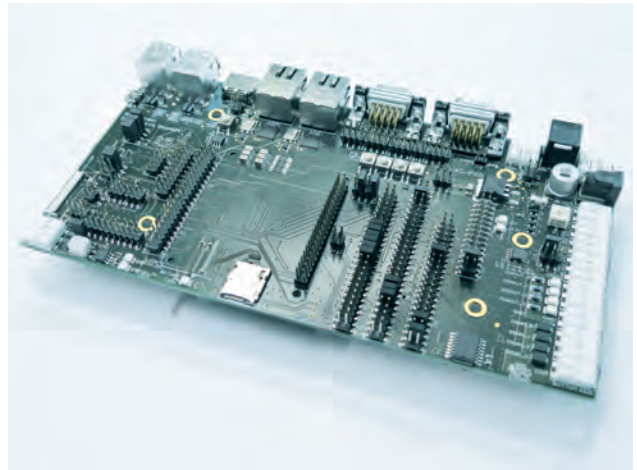

Figure 1: Raspberry Pi starter kit product photo (Source: Kontron)

Meanwhile, Kontron Electronics has completed the first commercial projects based on Raspberry Pi and can draw first conclusions. Counter to intuition, but not unexpected from a professional standpoint, the platform's low starting price doesn't translate to a low price in volume production for industrial use. It has been shown that for prototypes based on Raspberry Pi, converting them into an industrial product ready for series production requires consultation. In some cases, the resulting industrial platform is no cheaper than a standardized embedded platform. Kontron Electronics can even point to applications in which, after the consulting phase, it became apparent an industrial standard product was more cost-effective for series production overall.

## Price does not always speak in Raspberry's favour

Often, however, the price is not the only decisive argument: What is sometimes more important about Raspberry is the software's ease of use. The Linux-based Raspberry operating system Raspian OS is very easy to use. Software packages can be easily installed subsequently, which saves time. Embedded Linux, for example, is much more difficult to install and administer. Here, too, the reason for its simplicity lies in the fact that the Raspberry was originally only intended for use in research and education.

This lies at the heart of yet one more reason speaking for the use of Raspberry: the available support from a worldwide community of fans and specialists, which no



## Developer kit for Raspberry Pi

The developer kit for Raspberry Pi from Kontron includes a developer board compliant with SBC specifications, a Raspberry Pi Compute Module 3 Light, and an SD card with pre-configured Raspian operating system. With this offering, Kontron meets the development department's needs of various industries that develop prototypes based on Raspberry Pi, but have so far been reluctant to use the platform in industry due to a lack of professional support. In addition, many applications and programs that are freely available for Raspberry Pi from the open source community can now be used in industrial applications without any additional development effort.

commercially oriented company is able to offer. Particularly the fact that many students and young "makers" are committed to Raspberry leads to a high degree of openness and helpfulness, as is the case in social networks, which companies can also benefit from.

The size of this community also shows another advantage: the Raspberry platform was sold around 18 million times in total (as of early 2018). No standard industrial PC can match the size of this user base. A higher test coverage is virtually impossible, and the platform is correspondingly well-developed, which is why the "hobbyist" image is not as accurate as is often claimed.

The open source basis of the operating system and many applications, on the opposite, are only of limited benefit to industrial users. Although many applications are available under a free license, any adapted source code must also be published under the free license. Of course, many commercial companies find this difficult when the software "they own" has to be made available to everyone free of charge. The situation is not much different when individual modules from existing applications are used. Usually, programs derived from these modules have to be published under a free license in turn. However, those who are not dependent on Linux have the option of running Windows IoT core on the platform.

## Disadvantages to be considered

Nevertheless, there are also disadvantages in the industrial environment for the use of Raspberry Pi that should not go unmentioned. One is the lack of standardization compared to standards such as Smarc, COM Express, or Qseven. In addition, the Raspberry is only marketed by the Raspberry Foundation or its distributors. Therefore, there is no variety, e.g. in terms of performance, power consumption, or equipment.

There are currently only two generations of processors available as compute modules: The Compute Module 1 from 2014 and the Compute Module 3, which was introduced early in 2017. Raspberry does not offer Intel, AMD, or NXP processor options for different applications. ▶

# J1939 CAN-READY PANEL ALARMS ?



The industry leader in audioalarm technology is now CAN-Ready! Use our audibles on your existing J1939 CAN network to emit LOUD alerts in a small panel-mount design.

- Optional manual volume control
- 10 discrete digital volume levels
- Many available tone-types/sounds
- Arbitrary address capable
- Tamper-proof front-mount design
- Corrosion-resistant sound diaphragm
- Manufactured in USA
- Waterproof design (IP 68 and NEMA 4X seal)

**1-888-Floyd-Bell**  
or  
**www.FloydBell.com**



**Floyd Bell Inc**  
SOUND SOLUTIONS



Guaranteed long-term availability beyond seven years, such as Kontron offers for many standard industrial PCs, is not available for Raspberry Pi.

These disadvantages also show why a general statement as to which applications or industries the Raspberry is suitable for cannot be made. The choice usually depends on the application. Companies such as Kontron Electronics therefore offer an industrial starter kit, which can be used to quickly determine whether the Raspberry compute module meets the requirements. The starter kit has all the interfaces commonly used in industry, such as CAN, Ethernet, 1-wire, and EIA-485/EIA-232.

Especially the CAN network is used very often in the industry from automotive to automation products. Also the famous industrial protocol CANopen can be used, there are ports for the Raspberry Pi and also online tutorials. In some automotive application they are using the J1939 CAN protocol also therefore ports for the Pi can be found. The tried-and-tested circuit design and the standard industrial 24 Volt power connection ensure reliable usability. Further industrial analog and digital I/Os allow integration into predefined applications. The starter kit can be used to significantly shorten the path to the prototype and then to the finished product.

### Raspberry application example in hospitals

In co-operation with a customer, Kontron Electronics has developed a mobile solution for the continuous real-time recording of vital data of bedridden patients. A contactless, concealed box located under the hospital bed measures and records vital data, and alerts nurses and doctors in the event of serious deviation. No direct patient contact is required to record heart rate, respiratory rate, decubitus, and fall prevention data. Thanks to the battery operation, the box can be easily installed under any bed.

During the hardware's development, the following technical requirements were also in the foreground: Linux support - in this case, yocto Linux was to be used; support for several interfaces such as WLAN, LAN, and Bluetooth; high computing power, which also allows machine learning; as well as the integration of an additional independent processor to guarantee the measuring results.

### Certification as a medical device possible

In general, the product should of course be certifiable for use in a clinical environment: it should be approved as a Class 2b medical device, which corresponds to the second-highest class, such as for anesthesia and respiratory equipment. It should also comply with EN 60601, which defines safety and ergonomic requirements for medical electrical equipment and medical systems. In addition, fast implementation, long-term availability, and a good price-performance-ratio were required.

Together with the customer, it was decided to use Compute Module 3 for the product. Compared to the requirements, it had disadvantages in terms of power consumption and long-term availability. However, the

advantages in computing power, Linux support, and not least in the price-performance-ratio, made up for the disadvantages in this case.

The implementation was completed quickly due to the starter kit; the prototype's electromagnetic compatibility tests (which are most important for clinical environments) were satisfactory from the get-go. The interfaces could be verified very quickly with Raspian OS. Some problems arose around the transfer of the prototype to yocto Linux, but were solved with some help from the community, as well as the professional know-how from the S&T, which Kontron Electronics is a part of. ◀



#### Author

Andreas Schlaffer  
Kontron Electronics  
[info.ebbs@kontron.at](mailto:info.ebbs@kontron.at)  
[www.kontron.com](http://www.kontron.com)





## TTConnect 616

TTConnect 616 is designed for application development and support of Ethernet in vehicle network architectures. Besides providing switch functionality, TTConnect 616 can also act as an inter-domain gateway controller, connecting different vehicle domains in a safe, secure and reliable manner. Its wealth of interfaces makes TTConnect 616 an ideal solution for future-proof vehicle architectures:

- 100BASE-T1 BroadR-Reach® 100 Mbit
- 100BASE-TX Ethernet for diagnostics and flashing
- CAN-FD, 125 kbit/s up to 5 Mbit/s
- LIN

## Partner program with quality label



*Many micro-controller manufacturers have a tool and software partner program. ST Microelectronics has established additionally a quality label.*

The French-Italian chipmaker, ST Microelectronics, is further increasing the market appeal of its STM32 micro-controller family by launching the “MadeForSTM32” label for qualified, reviewed, and approved products from the company’s partners in the development ecosystem. Engineers designing with micro-controllers rely on the ecosystem that provides configuration and development tools, ready-to-use software examples and libraries, and printed circuit boards to prototype their applications and bring them into production. Because those embedded systems require a standardized embedded CAN network, CANopen and J1939 protocol stacks are needed. The protocol stack vendors Emtas, Microcontrol, Port, and Simma are taking part already in ST’s partner program.

For many designers, the quality and effectiveness of the ecosystem is an important factor when choosing among micro-controller manufacturers for current and future designs. The STM32 family offers an already ecosystem that provides important software products and evaluation boards for developing with STM32 devices. Addressing the constant aim of helping customers find a solution for their design, ST is launching the “MadeForSTM32” program to review and qualify offerings from ST partners within the STM32 ecosystem. The quality label ensures

that all products within the ecosystem are of consistently high quality. “Our new label provides robust assurances for product designers by highlighting our assessment and approval of the quality and performance of third-party ecosystem products, as well as the customer support available,” said Daniel Colonna, ST’s Marketing Director. “There is added value for our ecosystem partners too, with branding using the MadeForSTM32 logo for approved products and literature, promotional opportunities, and access to the results of our technical evaluation to help drive continuous product improvement. The benefits of this program to both engineers and partners encourage significant expansion of the STM32 ecosystem with high-quality products.”

Seeger’s Embos and Unison’s Rowebots real-time operating systems (RTOS) have already been assessed and endorsed to become the first qualified approved pieces of embedded software. Other products are currently being evaluated. Microcontrol has submitted its protocol stacks for CANopen, CANopen FD, and J1939 for approval.

The chipmaker has promoted an open approach to maximize the choice of ecosystem products and services available to users of its STM32 micro-controllers. The introduced quality label now raises the bar by providing ▶



a structure for assessing key attributes of partners' ecosystem products, and a label that vouches for quality, performance, and dependability. Any ecosystem partner can submit a product for evaluation and, after a successful review and approval, use the quality label. Embedded software such as CANopen or J1939 protocol stacks must be compatible with the STM32Cube ecosystem, packaged as a software expansion for STM32Cube, and demonstrated running on appropriate STM32 boards. All products must be currently available to any customer as well as supported and maintained.

The STM32 family comprises 900 variants. Many of them are equipped with Classical CAN and CAN FD interfaces.

hz

### CANopen protocol stack in ANSI-C

Emtas offers for the STM32 micro-controller family a CANopen protocol stack with NMT master/slave functionality, which conforms to CiA 301 version 4.2. It is written in ANSI-C and it is compliant with the Misra coding rules. As an addition the company provides all necessary tools for development and test of CANopen devices and networks. A special framework for the CANopen-based Energybus is available, too. The CANopen protocol stack is distributed by the HMS brand Ixxat. Microcontrol, Port, and Simma provide also CANopen protocol stacks for the STM32 family. Microcontrol's CANopen boot-loader protocol stack provides the complete functionality for integration of a bootloader according to the CANopen standard in CAN-connectable devices. Versatile configuration options facilitate individual customization to a target product. In implementation of the boot-loader special emphasis was placed on low storage requirements. The CANopenNode (Github) open-source project supports the micro-controllers, too.



# Knowledge transfer

CiA provides several education services for different purposes:

### CiA seminars

Explanation of the basics of CAN (FD) and CANopen (FD).

	Date*	Language	Location
CAN for newcomers	2019-10-08	German	Nuremberg, DE
CANopen	2019-10-09	German	Nuremberg, DE
CAN FD	2019-10-22	English	Frankfurt/Main (DE)
CANopen FD	2019-10-23	German	Frankfurt/Main (DE)
CANopen safety	2019-11-19	German	Nuremberg, DE
CAN for newcomers	2019-12-04	English	Nuremberg, DE
CANopen	2019-12-05	English	Nuremberg, DE

### CiA in-house seminars

In-house seminars, tailored to your company's specific needs.

### CiA webinars

Reports on trends in the application field of CAN.

	Date*	Language
CiA 447 car add-on modules	2019-09-26	English
Future of CANopen FD	2019-10-17	English
CANopen & IoT	2019-11-21	English
Future of J1939 based on CAN FD	2019-12-12	English

### CiA individual webinars

CAN-related topics of your special interest.

\* Subject to change without notice.



For more details please contact [events@can-cia.org](mailto:events@can-cia.org)

[www.can-cia.org](http://www.can-cia.org)

# “The trend is to go to open platform telematics”

Everyone talks about “Internet of Things”, “big data”, and “cloud” services. But nobody wants to buy additional hardware to get access to the CAN-based in-vehicle networks.



Figure 1: Vision of fleet telematics in 2025 (Source: Frost & Sullivan)

The last two years were intense and in the same time brought an air of change in telematics industry. According to the studies and reports that are available, at this point many acquisitions and optic changes took place in the market. In addition, the requirements in the market are different and the regulations are new. The trend is moving to “smart” cities approach, “smart” mobility and self-driving transportation.

What about the other industries? What are their requirements and what are the trends? How wide is the offer? Can the hardware offered still fulfill all demands? Sure is that technology advances and demographic needs are changing, mobility industry is pushing telematics to come up with new solutions, and the providers are trying to keep up the step with the innovation trends. Everything will go electric or autonomous, everything should be in one place but shared and opened to the others, the data are still the gold but how they are shapes is the real treasure.

In the automotive industry, if we talk about small passenger cars or big fleet of trucks, the main aspect in the discussion is the value gained by using each type of vehicle. Mirroring this into services area the focus is similar and it is moving from TCO (total cost of ownership) to value created. The users are looking for solutions that are more reliable with the possibility of updating them in time without adding any new hardware. Soon we will talk about vehicle as a service, car as a service, or vehicle as a marketplace. The value will consist in the number and quality of the application accessed in each vehicle or telematics devices.

We understood this opportunity and in 2019 we decided to go outside the box in the real way. Even, if we will still maintain the hardware as part of their business, we have decided to open our solutions and license our knowledge to third-party telematics devices that are open platform based. As the recipient of the 2018 for Customer Value Leadership Award for CAN-based solution named by Frost and Sullivan, this move looks like offering to all telematics players the same value for their solutions and products.

Changing the focus from TCO to value growth enables in the same time many other adjacent or complementary opportunities like smart mobility projects, smart cities solutions based on car sharing and ride sharing vehicles, ▶



Figure 2: The CAN Library supports a broad range of use cases (Source: Cango)





Figure 3: Bianca Barbu (Chief Marketing Officer, Cango) at the 5<sup>th</sup> Telematics Conference in Dubai, March 2019: "All the functionalities that we offered until now inside our hardware are ready to be offered as applications on third party open platform telematics units. In this way we want and we are able to license our knowledge in any telematics devices and it is not only CAN libraries but also we build applications like Driver Performance Assistance, MIL&DTC codes, Tachograph, FMS2IP, car sharing, or any other application that a partner can imagine." (Source: Cango)

smart public transportation. In a world full of sensors and connectivity, being open and prepared for the new challenges is the key to success in telematics business.

Our CAN-related services empower any telematics supplier provider to read any vehicle data in any industry. The approach is quite simple and it is based on an operating system that is free and easy to access: Android. The CAN-related services for Android run in the background of any 3<sup>rd</sup> party telematics device without any user interaction or interface, except the one for configuring it. The service runs with a higher priority than inactive or invisible activities and therefore it is less likely that the Android system terminates them for resource management.

From now on using our CAN-related service, any 3<sup>rd</sup> party device will act like a firewall necessary to safeguard against hazards caused by interference with vehicle computer systems.

The main advantage of this type of service is, that based on it, an unlimited type of application can be built. In this way, the final user, instead of paying for a new additional hardware if they need a new functionality or feature for their fleet, will only add the application. Getting this type of solution the final client will gain the most advantages in the first place because there will be no time and costs spent with the installation and integration of a new hardware. Also, there are many advantages for the telematics solution providers because they will always be ready for the new challenges of the market and requirements of the clients.

The main advantages and benefits that the CAN-related service are the flexibility and control. Moreover, in this situation we are talking about real-time remote control with everything settable and a zero rate of failure and 100-percent data accuracy.

The CAN library is the base for any telematics application that can be developed. As mentioned, there is no need

to add any new hardware to get the TPMS because there will be an application for it. Also applications for trailer data without any external device or an application for the DTC codes and MIL. One of the most important applications is the Lucas driver performance assistant, which coaches the vehicle conductor in real-time by calculating more than 49 parameters. All the application can be combined with artificial intelligence or machine learning to evolve to predictive traffic, usage-based insurance, avoiding collisions, or anomalies on the road.

The trend is to go to open platform telematics, which opens opportunities for other industries, and helps achieving the objectives related to the regulations around the world in increasing the quality of life by decreasing the CO<sub>2</sub> emission and saving more fuel. This business model proposed by us is the answer to the question: Is there an all-in-one solution that can be updated anytime, over-the-air, with the latest developments on the market and with minimum costs? ◀



#### Author

Bianca Barbu  
Cango  
[office@cango.ro](mailto:office@cango.ro)  
[www.cango.ro](http://www.cango.ro)

### DIN 4630: The link for vehicle body builders to the cloud

Engineers from OEMs, suppliers, and vehicle body builders develop jointly the DIN 4630 standard. It specifies a CAN-based network using CANopen or J1939 as application layers. The purpose is to transmit via CAN data from the body applications such as tail-lifts or refrigerating units to a telematics unit. The specified network also provides links to the in-vehicle networks, e.g. the FMS (fleet management system) or the body builder gateway. The standard under development also supports the addressing of sub-devices in more complex body applications such as fire-fighting trucks or refuse collecting vehicles. The main use-cases of DIN 4630 are pre-emptive maintenance and condition monitoring. The standard does not specify security measures.

hz

## Galvanic-isolated CAN FD transceivers

*Analog Devices and Texas Instruments offer galvanic-isolated transceivers for CAN FD networks. These components comply with ISO 11898-2:2016.*

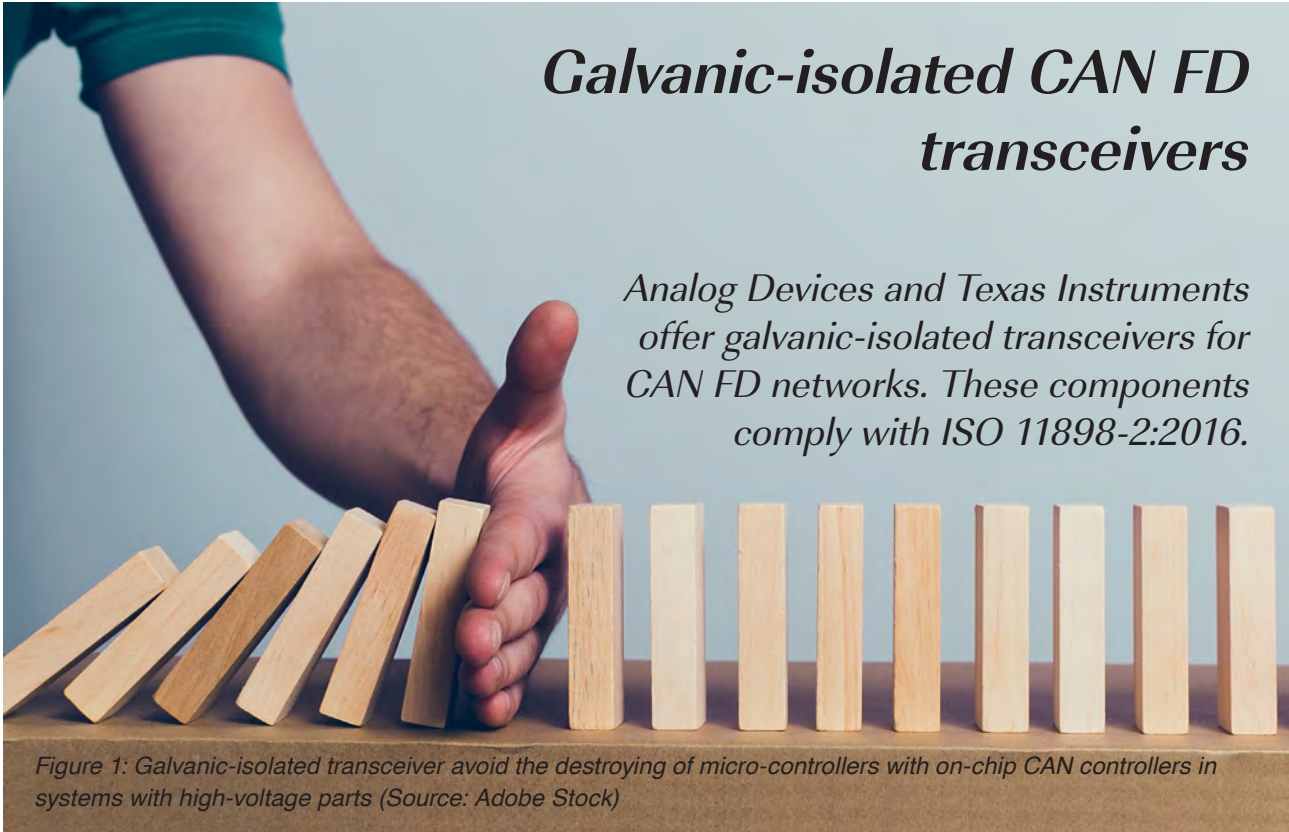

Figure 1: Galvanic-isolated transceiver avoid the destroying of micro-controllers with on-chip CAN controllers in systems with high-voltage parts (Source: Adobe Stock)

In many non-automotive applications with long networks galvanic-isolated transceivers are required. In such long networks, connected devices can have differences in local earth potential. Additionally, different supplies may power the devices. But also in electrical-powered vehicles there is an increasing demand on isolating high-energy components from the low-power ECU (electronic control unit) circuitry. Therefore, in some Classical CAN as well as CAN FD networks bus-signals as well as power-lines needs to be isolated. This can be achieved by different methods. External optocouplers or transformers are widely in use. In order to reduce the number of physical interface components, semiconductor manufacturers have launched since some years CAN transceivers with on-chip isolation circuitry.

Recently, Analog Devices and Texas Instruments have improved their galvanic-isolated CAN transceivers to meet the requirements of ISO 11898-2:2016 regarding the new symmetry parameters. The ISO standard specifies two sets of symmetry parameters. Depending on the network design, you can achieve data-phase bit-rates of 2 Mbit/s respectively 5 Mbit/s or more. If your requirement regarding the temperature range is not challenging, you can run your CAN FD network at bit-rates up to 12 Mbit/s. But temperatures below 0 °C limit the transmission speed in the data-phase dramatically.

Besides the network topology, the cable selection is critical depending on the impedance over the specified temperature range. CiA has released the CiA 601-6 CAN FD cable recommendation. The most suitable topology is a bus-line with very short stubs. The sample-point setting in the data-phase is an important issue to achieve a high bit-rate in the data-phase. The CiA 601-3 recommendations

give some guidelines for an optimized sample-point setting including the secondary sample-point.

The offered galvanic-isolated CAN transceivers conform to the improved set of symmetry parameter set. The products by Analog Devices specify a minimum of 50 ns and maximum of 91,6 ns for the loop-delay symmetry. This is better than what ISO 11898-2:2016 requires (120 ns minimum and 220 ns maximum). The loop-delay symmetry of the Texas Instruments product is typically 150 ns.

### Products by Analog Devices

The galvanic-isolated transceiver by Analog Devices employs the iCoupler technology to combine a 2-channel isolator and a transceiver into a single small outline integrated circuit (SOIC) surface-mount package. This technology is based on on-chip dc/dc converters. The launched transceivers (ADM3050E, ADM3055E/57E, and ADM3056E) feature a 5-kV respectively 5,7-kV RMS (root-means-square) bus-signal isolation voltage. They provide the usual protection circuitry for  $\pm 40$ -V on the bus-lines as well as over-temperature and permanent dominant bus-states. The chips also provide an extended common-mode range of  $\pm 25$  V.

The CAN FD connectable devices must add protection against harsh operating environments while also should be as small as possible. To reduce board space and the design effort needed to meet the system-level ESD standards. Therefore, the introduced transceivers provide protection circuitry on chip for the CAN\_H and CAN\_L pins. ▶



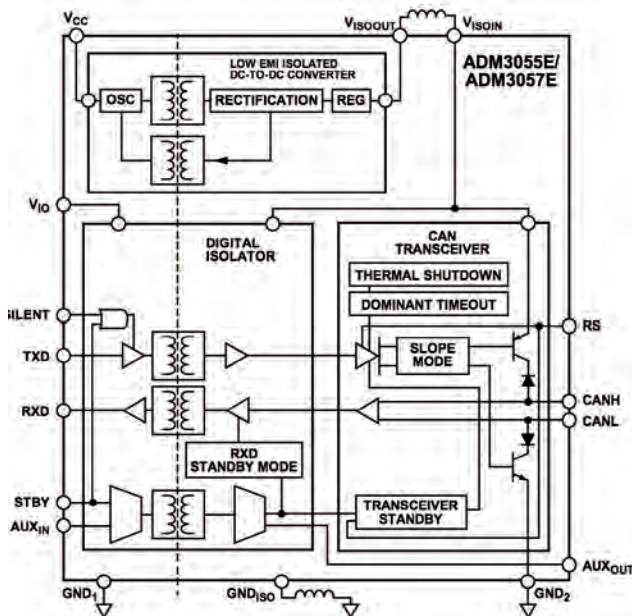

Figure 2: Block diagram of the ADM3055E/57E transceiver (Source: Texas Instruments)

Wiring accidentally high-voltage to bus-lines is frequently made mistake in production lines. Supplies can also be short-circuited by accidental damage to the cables while the system is operating. Accounting for inductive kickback and switching effects, the bus lines are protected with up to nominal 24-V supplies. The signal lines can

withstand a continuous supply short with respect to GND2 or between the bus lines without damage.

In cases, in which the TXD input pin is allowed to float – to prevent bus traffic interruption – the TXD input channel has an internal pull-up to the VDD1 pin. The pull-up holds the transceiver in the recessive state. The transceivers also feature a dominant timeout. A TXD line shorted to ground or malfunctioning CAN controller are examples of how a single-node can indefinitely prevent further bus traffic. The dominant timeout limits how long the transceiver can transmit in the dominant state. When the TXD pin is presented with a logical high, normal TXD functionality is restored.

The minimum transmit dominant-timeout also inherently determines a minimum bit rate. Under normal operation, the CAN protocol allows five consecutive bits of the same polarity before stuffing a bit of the opposite polarity into the transmitting bit sequence. When an error is detected, the CAN controller purposely violates the bit-stuffing rules by producing six consecutive dominant bits. At any given bit rate, the CAN controller must transmit as many as 11 consecutive dominant bits to effectively limit the transceivers minimum data rate to 9600 bit/s.

The transceivers comprise thermal shutdown circuitry that protects them from excessive power dissipation during fault conditions. Shorting the driver outputs to a low-impedance source can result in high driver currents. The thermal sensing circuitry detects the increase in die temperature under this condition and disables the driver outputs. The ▶

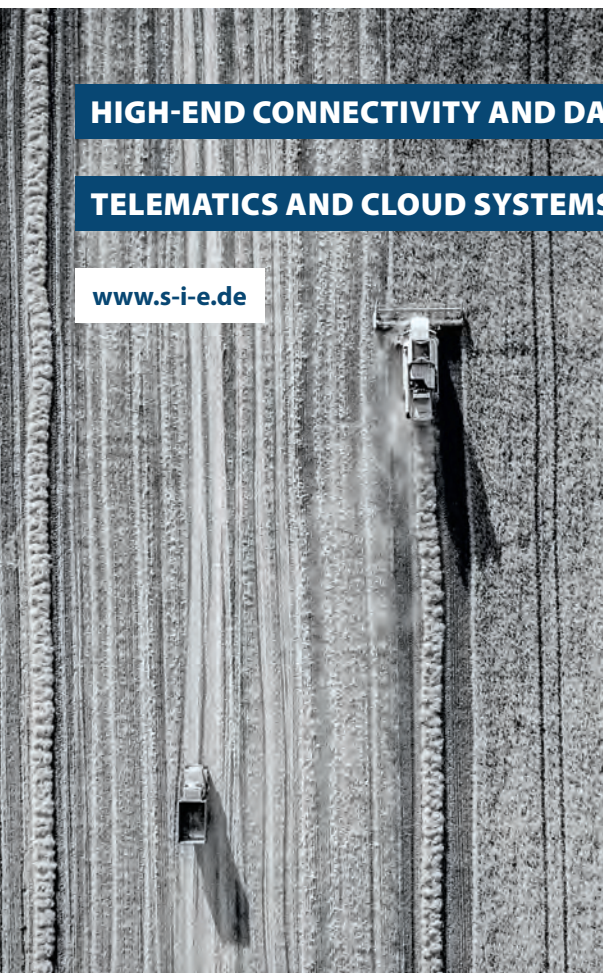

**HIGH-END CONNECTIVITY AND DATA MANAGEMENT**

**TELEMATICS AND CLOUD SYSTEMS FOR IOT AND SERVICE 4.0**

[www.s-i-e.de](http://www.s-i-e.de)

Sontheim

### Continuous digitization for smart vehicles

Modular on-board units with Linux – ready for condition based monitoring. Including flash-over-the-air and embedded diagnostic functionality.

Sontheim IoT Device Manager and IoT Analyze Manager – for a highly secure, comfortable and individual visualization and management of your data.

### Telematic ECU – COMhawk® xt



IoT Device Manager and IoT Analyze Manager



Integrated flash-over-the-air functionality



Modular on-board telematics series



Embedded diagnostics functionality



Multi-protocol support (J1939, J2534, UDS, KWP, ...)



Ready for condition based monitoring

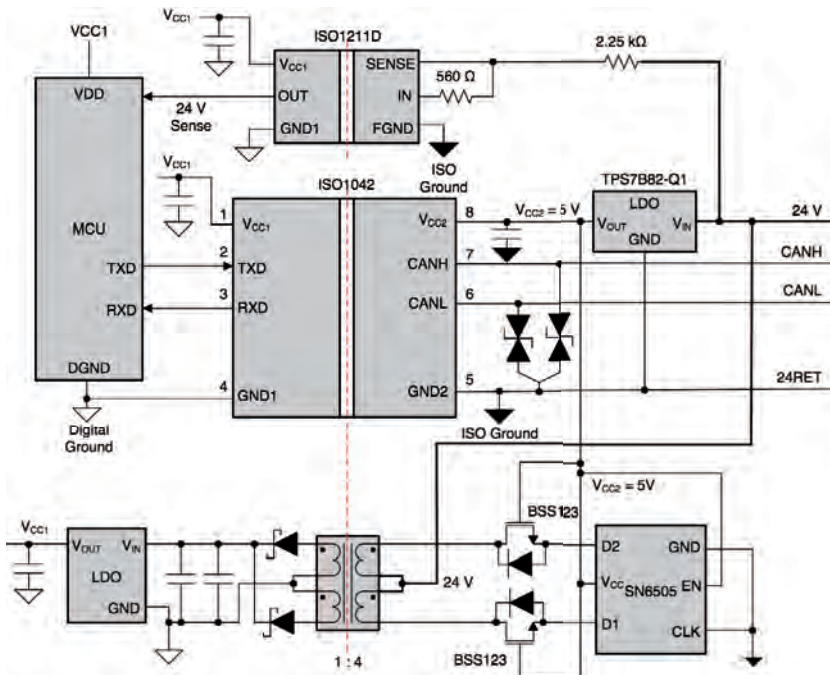

Figure 3: Typical interface for Devicenet nodes using the ISO1042 transceiver (Source: Texas Instruments)

circuitry disables the driver outputs when the die temperature reaches 175 °C. When the die has cooled, the drivers are enabled again.

The ADM3056E and the ADM3055E/57E transceivers support the optional low-power mode as specified in ISO 11898-2:2016. Formerly, there was a separate standard for this function, but now it has been included in the updated ISO standard. In the stand-by mode the TXD signal isolation channel is disabled. The transmitter output is set to a high-impedance state loosely biased to GND2. While in stand-by mode, the receiver filters bus data and responds only after the remote wake-up sequence is received. When entering or exiting stand-by mode, the TXD input must be kept high and the RXD output must be ignored. When the remote pattern as specified in the ISO standard are on the bus, the transceiver is still in low-power mode as long as the STBY pin is high.

The ADM3055E/57E transceivers feature a non-standardized silent mode. In this mode, the TXD digital isolation channel is disabled. Any inputs to the TXD pin are ignored, and the transceiver drives a recessive bus state. The operation of the RXD channel is unaffected. The RXD channel continues to output data received from the internal CAN transceiver monitoring the bus. This mode is useful when paired with a CAN controller using automatic bit rate detection. A CAN controller must be set to the same bit rate as all attached nodes. The CAN controller produces an error frame and ties up the bus with a dominant state when the received data rate is different from expected. Other CAN nodes then echo this error frame. While in silent mode, the error frames produced by the CAN controller are kept from interrupting bus traffic, and the controller can continue listening to bus traffic to tune.

Recently, Analog Devices acquired Linear Technology and inherited the LTM2889 galvanic-isolated transceiver. It is suitable for CAN FD applications and features symmetry parameters above the basic set and below the

extended set as specified in ISO 11898-2:2016. According to the CiA 601-3 bit-timing recommendations it fits for 4-Mbit/s data-phase bit-rates using a bus-line topology with short stubs. The transceiver can be powered with 3,3 V or 5 V. It also provides a dominant time-out function (0,5 ms to 4 ms).

## Products by Texas Instruments

Texas Instruments has developed the ISO1042 transceiver chips, which features a  $\pm 70$ -V protection. It also conforms to ISO 11898-2:2016 and provides the optional low-power capability. If sleeping, it can be woken up by bit-pattern as specified in ISO 11898-2:2016. The loop-delay is 152 ns. The common-mode voltage range has been extended to  $\pm 30$  V. The transceiver suitable for a temperature range from -40 °C to +125 °C comes in an SOIC-16 or an SOIC-8 package.

The transceiver uses a silicon dioxide (SiO<sub>2</sub>) insulation barrier with a withstand voltage of 5000 VRMS and a working voltage of 1060 VRMS. Electromagnetic compatibility has been enhanced to enable system-level ESD, EFT, surge, and emissions compliance. Used in conjunction with isolated power supplies, the chip protects against high voltage, and prevents noise currents from the bus from entering the local ground.

The TXD DTO (dominant time-out) circuit prevents the transceiver from blocking network communication in the event of a hardware or software failure, which holds the TXD pin dominant longer than the timeout period (1,2 ms to 2,8 ms). The DTO circuit timer starts on a falling edge on the TXD pin. The DTO circuit disables the CAN transmitter, if no rising edge occurs before the timeout period expires, which frees the bus for communication between other nodes on the network. The CAN driver circuitry is activated again when a recessive signal occurs on the TXD pin, clearing the TXD DTO condition. The receiver and RXD pin still reflect activity on the CAN bus-lines, and the bus terminals are biased to the recessive level during a TXD dominant timeout.

Of course, the transceiver is protected against over-temperatures (170 °C). If the junction temperature of the component exceeds the thermal shutdown threshold, it turns off the CAN driver circuitry, blocking the TXD-to-bus transmission path. The CAN terminals are biased to the recessive level during a thermal shutdown, and the receiver-to-RXD path remains operational. The shutdown condition is cleared when the junction temperature drops at least the thermal shutdown hysteresis temperature (5 °C) below the thermal shutdown temperature.

Unlike an optocoupler-based solution, which requires several external components to improve performance, provide bias, or limit current, the ISO1042 only needs an external bypass capacitors to operate. The transceiver is available in an industrial version and in a Q1-qualified ▷



version for automotive applications. The non-automotive CAN-based system approaches (e.g. Arinc850, CANopen, Devicenet, and NMEA 2000) add system-design aspects. They lead to system-level tradeoffs for bit rate, cable length, and parasitic loading of the bus-lines.

The ISO1042 components are specified to meet the 1,5-V requirement with a 50-Ω load, incorporating the worst-case including parallel transceivers. The differential input resistance of the transceiver is in minimum 30 kΩ. If 100 of such transceivers are in parallel on a network segment, this requirement is equivalent to a 300-Ω differential load in worst-case. That transceiver load of 300 Ω in parallel with the 60 Ω gives an equivalent loading of 50 Ω. Therefore, the transceiver family theoretically supports up to 100 transceivers on a single bus segment. However, for CAN network design margin must be given for signal loss across the system and cabling, parasitic loadings, network imbalances, ground offsets and signal integrity: Therefore a practical maximum number of nodes is typically much lower. Bus length may also be extended beyond 40 m by careful system design and bit-rate tradeoffs. For example, CANopen network design guidelines allow the network to be up to 1 km with changes in the termination resistance, cabling, less than 64 nodes, and a bit-rate of 50 kbit/s.

### System design optimization

This flexibility in network system-design is one of the key strengths of the CAN technology. Optimizing the CAN net-

work system to different criteria requires a deep knowledge in electronics, in order to balance the mentioned tradeoffs. Standardized solutions unburden the individual system designers from this.

The launched transceivers with galvanic-isolation capability, simplifies the CAN interface design on the device-level. But mixing of such transceivers from different vendors in the same network needs additional investigation to meet the system-design requirements. ◀

hz

*based on information of Analog Devices  
and Texas Instruments*

## CAN and CAN-FD Products for your requirements



CPC-USB/FD



EtherCAN CI-ARM9



CPC-USB/embedded

- Economical solutions for series applications
- Optimized for industrial applications
- Solutions for stationary and mobile use
- Software support for bus-analysis, measurement and control

**EMS**  
Thomas Wünsche

Sonnenhang 3  
D-85304 Ilmmünster  
Tel.: +49-8441-49 02 60  
Fax: +49-8441-8 18 60  
[www.ems-wuensche.com](http://www.ems-wuensche.com)

## Encoders for hydraulic and telescopic cylinders

*Draw-wire sensors based on rotary encoders have some advantages compared to other solutions. Matthias Roth, Siko's Industry Manager Mobile Automation explains them on the example of the SGH series.*

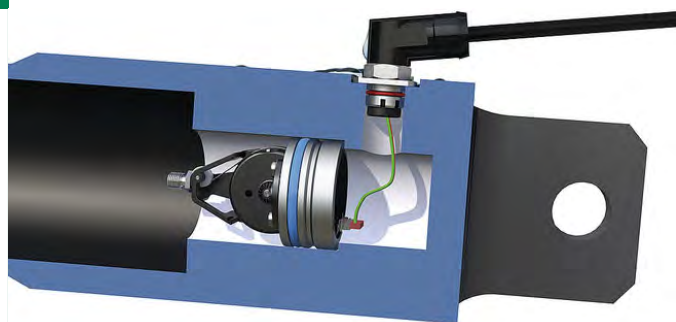

(Source: Siko)

**Q:** In summary: What is special about the SGH series?

**A:** With these wire-actuated encoders, we are the only metrology specialist to have a worldwide exclusive technique for measuring the position of hydraulic cylinders, telescopic cylinders, or piston accumulators. The wire-actuated encoder-based sensors can be fully integrated into cylinders. The advanced, cable-based concept of the sensors provides additional benefits, which comparable products cannot offer. For example, our sensors cover a very wide range of applications as well as entire measuring ranges. The used techniques also excel with regard to immunity against shock and vibration. It ensures absolute best values in this area. The cable-based functional principle also makes the sensors the only integrated position sensors in the world which can also be used in telescopic cylinders.

**Q:** How should we view the development of your sensor techniques?

**A:** We benefit from 30 years of wire-actuated encoder know-how in terms of development, design, and production. Of course, our development, product design, and ultimately the customer also benefit from this knowledge. Like the SGH10, which measures zero-to-one-meter lengths, our latest generation of wire-actuated encoder generators, we have developed by our own the SGH25 and the SGH50 measuring zero to 2,5 meters respectively from zero to five meters. Wire-actuated encoders are therefore our core competence. In this respect, it is not surprising that the entire design of the devices is done in-house. In other words, we specify parameters such as the correlation of forces, the spring characteristic curve or the number of revolutions depending on the respective product. This makes our sensors extremely robust and durable. Both electronically and mechanically, they are designed and

tested for the entire service life of the cylinder. The service life thus meets the quality requirements that have been posed to us by the market. And that is the most important criterion for us.

**Q:** What challenges were faced during the development?

**A:** Sensor solutions intended for hydraulic cylinders must fulfill a central requirement: they should not affect the length of a cylinder. In other words, by installing such a sensor, the length of the cylinder should ideally not increase or be minimal. To fulfill this requirement, we use an innovative functional principle that achieves a hitherto unknown compactness. The stroke measurement technique takes a completely different approach than other market-based measurement systems that use bar-based, inductive, or reverberation-based techniques. To record the stroke or movement speed, our sensors use flexible cable pull mechanics installed directly in the cylinder.

**Q:** How does it work?

**A:** The cable of the cable mechanism is fastened in the piston head. When the cylinder extends the cable, which is wound on a cable drum, gets pulled out. The drum turns, creating a rotation. This rotational movement is detected by the sensor electronics and converted into a linear position value. This makes it possible to detect the position of the cylinder precisely and completely at all times. Electronics, mechanics, and sensors are completely installed within the cylinder and therefore optimally protected against external environmental influences. This is a clear advantage over cylinder-external sensors, because in this way the entire sensor system cannot be damaged, negatively influenced by environmental influences or even destroyed. For this reason, the sensors are IP69K-rated.

**Q:** What does a protection class of IP69K mean?

**A:** IP69K guarantees the highest possible protection against external influences, which could jeopardize the functioning or the operation of the SGH system. This includes, for example, substances such as water, dirt, or dust. The requirements of this protection class are so high that the mechanics and electronics of the wire-actuated encoder must withstand the force of a high-pressure water jet without liquid or other substances being able to penetrate into the interior of the sensor. The sensors therefore ▶



use our KV1H connector systems to achieve these levels of protection.

**Q:** What is about electromagnetic compatibility (EMC)?

**A:** This is an important aspect. Because in mobile machines the sensors are supplied via the vehicle electrical system and they, unlike in the case of stationary machines, are subject to significant fluctuations and other external EMC influences, they must have very high electromagnetic compatibility. It protects against voltage surges, unexpected discharging or overcharging, which could be caused by external voltage pulses, to which these machines are exposed. Therefore, these applications require an extremely high degree of EMC, which is one hundred percent legally compliant and protects against malfunction and machine downtime.

**Q:** Are there other advantages of your sensor techniques as compared to other measuring systems?

**A:** Another advantage is its immunity to shock and vibration. Very strong impacts and shocks can occur especially in commercial vehicles such as construction or agricultural machinery, for example an excavator bucket which is set down hard on the ground, i.e. actually hits it. As a result, a very strong shock wave is created, which moves through the hydraulic cylinder, the piston, the piston rod, and up to the installed sensor. This can cause serious damage that will ultimately affect the operation of the system. On the other hand, if our wire-actuated encoder is used, the flexible cable fully absorbs this shock, so that the sensor operation is not disturbed and there is no downtime of the application containing the SGH sensor.

**Q:** Which digital interfaces are offered and what about safety variants?

**A:** Our sensors come with CANopen or SAE J1939 interfaces. For safety-related applications, redundant sensors with two interfaces or with CANopen Safety (EN 50325-5) interface are available. These sensor variants can be used in applications up to Performance Level d (PLd).

**Q:** What is about the costs for system integration in cylinders as well as logistics and warehousing?

**A:** The innovative concept of our sensors leads to an economically very advantageous and therefore even revolutionary situation regarding the integration costs. Our sensors do not have a fixed sensor rod, which in conventional systems must be completely inserted in the piston. The cable-based design of the wire-actuated encoder is therefore less expensive because it requires no additional piston drilling. By contrast, the cable is only mounted on a small thread on the piston. Furthermore, the logistics and warehousing for our sensors is negligible compared to bar-based measuring systems. Imagine being a manufacturer of five-meter-long hydraulic cylinders. In the case of a rod-based measuring system, a sensor that is around five meters long would have to be transported and stored.



*Mathias Roth, Industry Manager Mobile Automation  
(Source: Siko)*

In comparison, our SGH50 would not only be quick and easy to ship worldwide, but could also be stored, transported, and processed in the production process with minimal effort. The resulting huge savings for manufacturers of cylinders are obvious. Overall, the production time is reduced as substantially as the production costs. In this respect, the following rule applies: the amount of savings increases with the measurement length. In addition, our sensors are the only ones that can be used in telescopic cylinders. This gives us a real unique value proposition. In particular, the latest products with measuring lengths of up to 2,5 meters (SGH25) and up to five meters (SGH50) is in great demand in this area.

**Q:** Where else are the position sensors used?

**A:** Areas of application are generally to be found anywhere where the movements of cylinders have to be controlled and optimized. Of course, there is a particular focus on commercial vehicles. Wire-actuated sensors are integrated in hydraulic and telescopic cylinders of construction machinery, agricultural machinery, and forestry machines. Another area of application is piston accumulator. Again, they excel due to their outstanding compactness. The sensors can be installed in the gas area of the piston accumulator to save space. The general rule is that our sensors not only optimize motion sequences, but also the entire development and production process along with servicing, as well as easing the overall cost situation. Due to the flexible integration, they offer unprecedented possibilities in cylinder design. For these reasons, our sensors are more than merely attractive as an equipment option for cylinder stroke detection. ◀

## Swedish shopping center with CANopen-Lift control system



In the Globen Shopping mall 29 lifts use CANopen Lift controllers (Source: Hisselektronik)

*One of the biggest projects with a CANopen-Lift control system in Sweden is almost done. The interview by Jonas Tomasson (Safeline Group) with Roger Wickman (Hisselektronik) gives some more details.*

In 2018, the Globen Shopping center just outside of central Stockholm decided it was time for a modernization of the nearly thirty years old lifts. With 29 elevators to be upgraded, it was important that the lift electronics were top quality and built to last a long time. With that in mind, the choice fell on Safeline as the provider of the lift electronics. Hisselektronik built the elevator. That meant all electronics, even the car interiors, were to be exchanged and the Thor CANopen-Lift controller from Safeline has been installed in all of the lifts.

**Q:** Why did the customer decide to go with a CANopen-Lift control system?

**A:** It is a very flexible system. From now on, they can choose any lift company they want for maintenance or repair jobs. The unique thing about Thor is the fact that it's built to work with, not adapted, to CiA 417 on a Linux platform. Any CANopen-Lift product can be implemented and do



*Roger Wickman,  
Technical Project  
Manager at  
Hisselektronik*

the job. This means they are no longer obligated to buy from the constructor of the lift. From now on, they choose and pay market prices both for services and products. That of course means a bigger range of services and products as you are not limited to the constructor of the lift. This is more value for the customer.

**Q:** How future-proof is the selected elevator controller?

**A:** Very. The open CANopen-Lift protocol means flexibility for the customer to choose any developer and manufacturer. It is continuously developed all the time with new updates and new functions. You can continue building the system with new features without having to change hardware. For instance, the new cloud service that Safeline is currently developing. Once it's done, the cabinets will be fully integrated from the start. Then, you can do everything from the comfort of your office as you would be able to do on-site. They can set timers, parking floors, etc. They can re-program their lifts from wherever on earth. Thor by Safeline is a really powerful controller with endless possibilities. ◀

### Safeline and Thor

Safeline is a Swedish lift safety company founded in 1995. The firm has provided clients with over 250 000 installations of lift safety products manufactured in Tyresö, Sweden. It is one of the largest independent manufacturers of lift safety products in Europe.

Thor by Safeline is the touch-based lift controller developed for CANopen-Lift and the modern European lift market. "It is equipped with all the features lift technicians might require from a lift controller – giving users macro control of their lift system and preparing it for the years to come," stated Roger Wickman.

hz





**Meet our latest multichannel Ethernet to  
CAN/CAN FD interface for DIN Rail mounting.**

## Features

- ▶ Four CAN/CAN FD channels
- ▶ Supports up to 4 add-on modules; analog, digital & relay options
- ▶ Smart clip system for easy mounting; no tools needed
- ▶ Programming function makes this ideal for test cell or end-of-line production test
- ▶ I/O modules communicate with the Kvaser DIN Rail SE400S-X10 using an optical bus, eliminating the need for connecting cables
- ▶ Control the I/O from Kvaser's standard API (via Ethernet) or from the master unit using Kvaser *t* programs

Find out more about the Kvaser DIN Rail SE400S-X10  
& add-on modules at [www.kvaser.com/din-rail](http://www.kvaser.com/din-rail)

## Four elevators controlled by CANopen Lift

Thor Engineering has supplied the control systems for the elevators in London's Labs house. Two of the four elevators serve ten floors.

The CANopen-based four-elevators group installed in the Labs building uses the Thor-NX-T2 controller. Intelligent Lifts & Escalators was the installing company. Hisselektronik provided the control cabinets. Two out of the four elevators serve ten floors, the other two elevators serve the parking garage floor additionally, resulting in a total of 11 floors. All four lifts are traveling with a maximum velocity of 2 m/s.

The control systems use embedded CANopen networks conforming to the CiA 417 application profile. Unlike CANopen device profiles, CiA 417 describes the complete lift control system, using fixed and pre-defined PDOs and CAN-ID. This minimizes the setup effort. A general approach on how a single-lift's devices are installed is shown in Figure 1.

Usually, the Thor-NX-T2 features two independent CAN interfaces. One is used to connect the devices used for the single lift's general functionality, the second interconnects the lift shafts and other lift group members with each other. The controller is the only device that is connected to both CAN interfaces.

The Labs house project is an example how the different device manufacturers join together, in order to

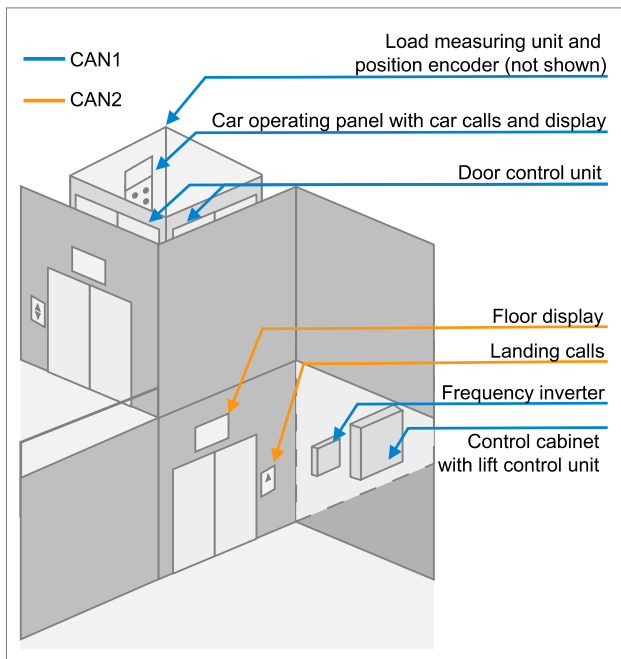

Figure 1: Exemplary usage of CANopen Lift on a single lift controller (Source: Thor Engineering)

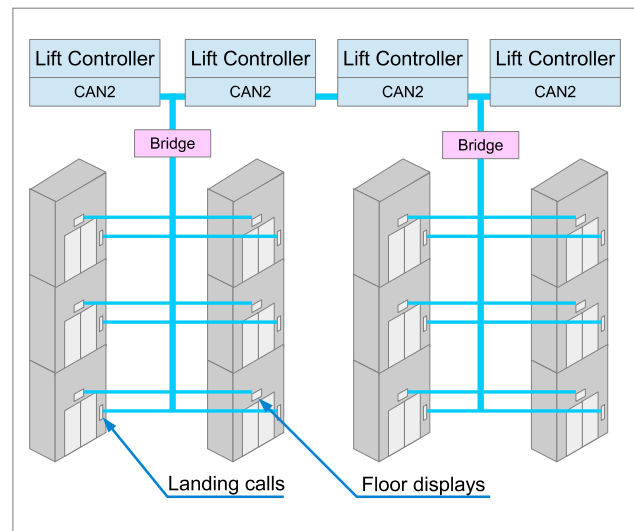

Figure 2: Example of a CANopen Lift system with four elevators (Source: Thor Engineering)

deliver a complete elevator system. All selected devices were compliant with the CiA 417 profile, to ensure a reliable communication and minimize the required work to setup the lift system.

To control the drive and thus the traveling speed, every lift system is equipped with a 4CS drive inverter by Ziehl-Abegg. The Limax sensor by Elgo provides the car position, which is directly connected to an LXC I/O-card by Safeline on top of the cabin. A 10-inch TFT Elfin is used inside the car as display unit. The car-call and the door-control buttons are connected to the IO8-boards by Safeline. The MiDrive door drive unit by Meiller opens and closes the car doors. All these mentioned devices communicate via the same CANopen network segment.

The second CANopen network comprises FD4 units by Safeline, which are used to handle the landing calls and to indicate the lift cars floor position on every floor. To be able to serve separate and parallel landing I/O threads over the hoistway distance, the CSI-01 units by Böhne + Partner are used as CANopen PDO bridges.

The Labs project demonstrates the capabilities and advantages of using CANopen Lift compatible devices. It is possible to connect devices from a variety of different manufacturers without complicated setup of PDOs and CAN-ID configuration. Each device collects and processes lift data using its manufacturer-specific



implementation, while maintaining compatibility in communication. Doing so, the companies can compete in functionality, but keep the CANopen lift system an off-the-shelf plug-n-play system. Devices can be exchanged, because they are interoperable. This means there is no dependency on a single supplier. ◀

## Interlift 2019

CAN in Automation (CiA) exhibits as usual at the [Interlift](#) tradeshow for elevator suppliers in Augsburg (Germany). From October 15 to 18, the organizer expects more than 21 000 visitors and more than 600 exhibitors. This year, CiA presents in [hall 2 \(Stand 2149\)](#) CANopen Lift devices from several members. Additionally, CiA staff is available to discuss in detail with visitors the features of the CiA 417 CANopen application profile for lift control systems. Beginning of this year, CiA 417 version 2.3 has been released, providing some new features and functional improvements.

The benefit of the CiA 417 profile specification for system designers is that you can scale the functionality to the dedicated lift control application. CANopen Lift is suitable for small elevators as well as for complex lift control systems. The specified functional entities comprise controllers and units. Nowadays, most of the available elevator controller systems provide the call controller, the car controller, and the car door controller in the same device. Of course, they could be implemented in separate devices.



The standardized units include input and output panels, car drives, car position sensors, and car doors. Light barrier and load measuring units are further traditional CiA 417 functional entities. In the last couple of years, units for power-measuring, remote data transmission, remote access, monitoring, and position supervision have been added.

The interoperability of these functional entities is tested by means of so-called plugfests. CiA members implementing the CiA 417 profile in their CANopen Lift devices proof jointly that their products interoperate. CiA organizes regularly plugfests.

hz

### Authors



Maik Hennemann, Roy Schneider  
Thor Engineering  
[hq@thor.engineering](mailto:hq@thor.engineering)  
[www.thor.engineering](http://www.thor.engineering)

## Designing a drive system is an interdisciplinary approach



(Source: Maxon)

*The drive system is a basic building block for the performance of machines, robots, and hand-held devices. However, there is much more to consider than just the design and the motor selection.*

Interdisciplinary thinking, specific engineering knowledge, depth of experience, and a clear understanding of the requirements are critical factors, when developing drive systems. Any kind of technological progress should focus on the application. At some point, improved performance characteristics or new technologies have to yield results in the form of better quality and/or reduced cost. With regard to drive technology for machines and hand-held devices, this means:

- ◆ better dynamics improve the production output,
- ◆ faster drive control improves precision and product quality, and
- ◆ a more efficient drive system improves the energy efficiency of the overall system.

In order to achieve these goals, drive systems must be selected in the overall context of the application and its requirements.

### The big picture

The first step in the specification and optimization of a drive system is to understand and correctly prioritize the technical and commercial requirements of the final system, which can be a machine, a robot, or a hand-held device. It's easy to miss the bigger picture and focus unilaterally on the considerations relevant for one's own field of expertise. As a rule, the drive selection happens in engineering. However, the performance, the cost, and the limitations of ▶



## Example: Integrated door drive system

Billions of people ride in elevators every day. Besides the main drive, elevators require compact door drives that are installed in the tight space above the door. The “smart” drives receive commands to open and close via a bus system. The drives need to execute these commands reliably and fulfill strict safety requirements. Together with a leading elevator manufacturer, Maxon has developed the door drive, which is capable of moving doors weighing up to 400 kg. This low-noise and energy-efficient drive system integrates a high-torque EC 90-flat motor with an encoder, an optional belt transmission, as well as an Epos positioning controller in one compact unit. The data exchange is implemented via CANopen. Specific control and force monitoring algorithms ensure smooth but dynamic door movement, precise positioning, and squeeze protection.

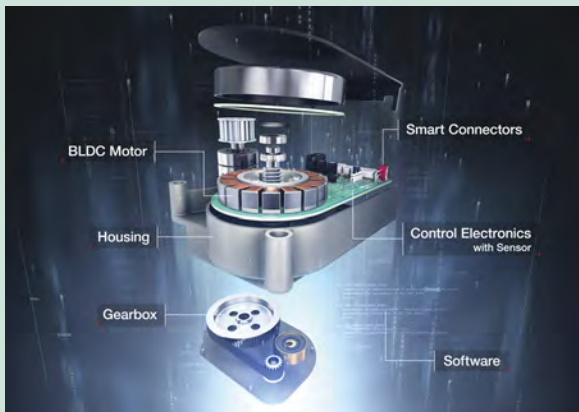

Door drive system (Source: Maxon)

Maxon designed and developed the system in collaboration with a customer, bringing together the interdisciplinary know-how of experts in application and safety technology, construction, controllers, electronics development, thermodynamics, and software. This kind of solution cannot be achieved simply by combining individual components: It requires the ability to design a new drive solution for a specific application case.

a drive solution are influenced by a multitude of factors as well as other system components. It is therefore critical to harness the know-how of experts from different fields during the idea and conceptualization phase.

## Pools of expertise

A system approach and interdisciplinary are two key success factors that should be considered from the concept design all the way to the mass production. Frequently, it is not possible to cover all competences in-house at the same level. External partners with a wide scope of experience provide an opportunity for a broader, interdisciplinary exchange of ideas. Ideally, the partner is also able to

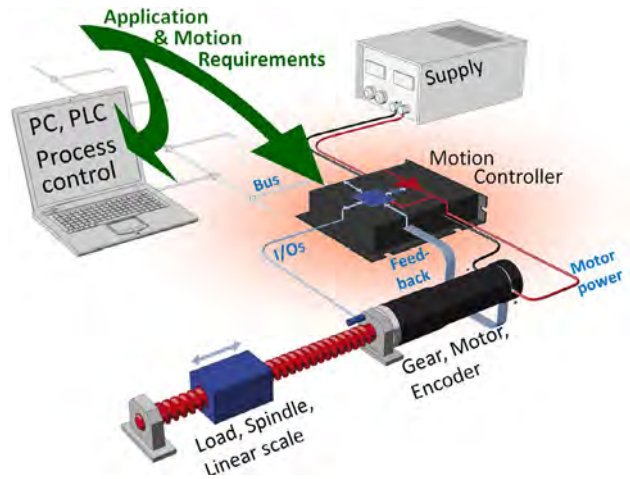

Figure 1: Building blocks of a drive system (Source: Maxon)

take responsibility for the development and production of partial systems, to reduce development risks and speed up the time to market.

With over 50 years of experience and more than 2600 employees worldwide, Maxon's scope of knowledge extends far beyond the “pure” drive motor. With in-house development and production, the portfolio covers brushless and brushed DC motors, gear-heads, spindles, encoders, motor controllers, master controllers, and battery management systems. Our products and customer-specific drive systems are used in robotics, medical and laboratory engineering, industrial automation, the automotive industry, and in aerospace applications from Earth to Mars. With many projects, the key factor is not just the broad product portfolio but also the interdisciplinary and depth of experience of our application teams, as well as the possibility of developing completely new drive solutions. Our experts for motors, gear-heads, electronics, and control are available in the early stages of discussing an idea and are familiar with the requirements of specific fields of application. Why covering various fields of expertise can be so decisive for a drive system becomes clear when we take a look at the individual components and their influencing factors.

## Focus on the host controller

A top-level “intelligence”, known as the “master”, transmits motion commands to the motor controller and queries process information (e.g. torque, speed, position, status).

- ◆ How the tasks are shared between the master and the motor controller is critical for assessing the required performance and selection of the master, the motor controller, and the communication interface.
- ◆ If fast cyclic data exchange (e.g. every millisecond) is needed in the machines, then a master with a real-time operating system (e.g. PLC) and a fast interface (e.g. CANopen) is required.
- ◆ If complex motion sequences can be pre-configured and executed autonomously in the motor controller, then it is sufficient to use a PC (common in lab automation), or a micro-controller (as used in hand-held devices, e.g. screwdrivers and drills from industrial automation or medical technology).

## Focus on the motor controller

The motor controller is the link between the top-level master and the motors as well as the feedback devices (e.g. encoders). Controllers and the power stage are used to convert current, speed, and position commands into voltages and currents in the motor phases.

- ◆ Fast controller cycles and complex algorithms enable precise and dynamic drive motions.
- ◆ State-of-the-art power stages deliver the peak currents required for fast acceleration. They have a high-energy efficiency. Integrated motor and signal filters improve the electromagnetic compatibility (EMC) and noise immunity.

## Focus on the encoder

Speed and positioning control require feedback devices (so-called encoders or linear scales) for returning information about the actual position of the motor and/or output shaft.

- ◆ The resolution and location of these encoders determine the theoretical precision limits of the positioning.

## Focus on the motor

The motor converts electrical energy into mechanical energy, e.g. into motion and torque.

- ◆ DC or BLDC motors with high overload capacity can have a compact design, because high torques are available for dynamic acceleration phases short-term.
- ◆ Motors with a low rotor inertia reduce the torque required to accelerate the rotor, thereby increasing energy efficiency and dynamics.
- ◆ High motor efficiency therefore improves the overall energy efficiency and reduces the heat generation, which is an important factor especially for hand-held devices.

## Focus on the gear-head

The precision, backlash, elasticity, and efficiency of the gear-head and the mechanical assemblies determine the output positioning accuracy, impact the dynamics (e.g. the

time after which the target position has been reached and stabilized), and play a role for energy efficiency.

## Challenges: Integration and battery operation

In order to integrate all components into a unit that is as compact as possible, it is necessary to consider the thermal aspects of mutual heating under load. To avoid costly redesigns, operating point calculations and thermal evaluations for the electric motor and the electronics should be done early on during the proof-of-concept stage.

Battery-powered applications require competence in energy efficiency optimization and battery management. ◀

### “A chain is only as strong as its weakest link”

This old adage also applies to the development and specification of complex drive systems. Engineering know-how and experience in design, electronics and control technology, as well as software engineering are all required when it comes to optimizing a drive for an application. We take pride in our ability to support its customers all the way from the initial idea to mass production and beyond, and to collaborate with customers for the development of specific system solutions when needed.



#### Author

Juergen Wagenbach  
Maxon Group  
[info.de@maxongroup.de](mailto:info.de@maxongroup.de)  
[www.maxongroup.com](http://www.maxongroup.com)



# DIY CAN TOOL

## WITH COLOR TOUCHSCREEN

### *Meet VividCAN!*

- Affordable, versatile, & customizable CAN tool
- Use as a field service tool with a simple touchscreen
- Perfect for field diagnostics, such as factory resets, configurations and localizations
- Ideal driver's aid for displaying drive profiles compared to actual values
- Use for executive display



### Key Features

- 60 FPS highly responsive display
- Capacitive display technology for easy and reliable operation
- Simple to configure with Vehicle Spy software
- Very quick startup (under 500 ms) with auto wakeup and startup features

Find out more: [www.intrepidcs.com/vivid](http://www.intrepidcs.com/vivid)

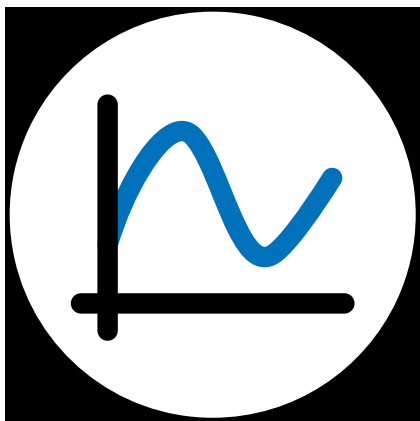

# INTREPID

## CONTROL SYSTEMS

[www.intrepidcs.com](http://www.intrepidcs.com)

+49 (0)721 1803083 -1

[icsgermany@intrepidcs.com](mailto:icsgermany@intrepidcs.com)

USA Germany UK Japan Korea China India Australia

# Status summary of CAN security specifications

*There is still no dedicated CAN security specification or standard released. Nevertheless, there are committed activities ongoing.*

In the last CAN Newsletter issue, the Micro CANcrypt concept was introduced, to show you how to add security to Classical CAN systems with limited resources both in terms of memory and performance. There, we used the additional 18 bits of a 29-bit extended CAN ID to add a digital signature. We promised you some hard, real-world numbers for both memory and CPU resources for this solution, however, got side-tracked by pursuing other CANopen FD customer projects.

Customer comes first, but once we have adapted Micro CANcrypt to run on a lower-performance micro-controller according to plan and have actually run it, you can expect to see an update in one of the upcoming CAN newsletters.

End of June 2019, the CiA association hold a phone conference for safety and security issues. Holger Zeltwanger gave the participants an update regarding “base documents”. When defining security solutions for Classical CAN, CAN FD, or CAN XL systems, it would be preferable to not start from scratch defining security basics for embedded systems or embedded communication systems. Unfortunately, the current draft of ISO 21434 “Road Vehicles – Cybersecurity engineering” does not seem to be suitable, as it is very generic and not yet completed. It is more of a guideline what designers and developers need to keep in mind when designing a “secured” vehicle. Another document suggested is the “Baseline Security Recommendations for IoT” by the European Union Agency for Cybersecurity. Until the next meeting, CiA will review and report, if that document is suitable to be referred to also by CiA documents.

CAN XL is still in an early specification phase and the related specialinterestgroup, recognizing the possibility for security features in hardware to be part of future CAN XL controllers, therefore suggested adding security features to CAN XL first. One of the discussed options is a blacklist/whitelist scheme like the one implemented by the NXP secure CAN transceiver family. Such a scheme can eliminate several potential attack

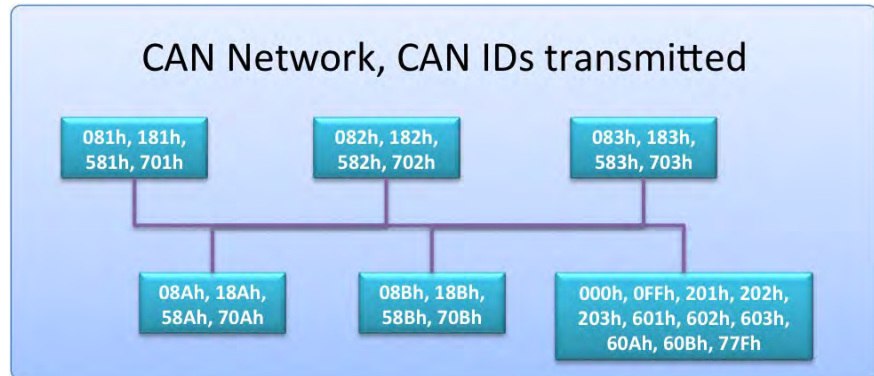

Figure 1: CAN-IDs used for transmissions (Source: Emsa)

vectors at once if all participants in a CAN (XL) network actively support it. Once we see which security features made it into the CAN XL specification (and hardware), we can review if any of these can still be applied to CAN FD, too, for example on the transceiver level. However, potential CAN controller specific hardware security features will most likely not be suitable to migrate back into CAN FD, so protocol based security solutions are still required.

## The essence of blacklist and whitelist handling

In a CAN system the use of the CAN IDs is unique, aside from some very special cases. For each 11-bit CAN ID (or 29-bit when using CAN extended frames) there is only one node in the system, which may transmit a CAN data frame using this CAN ID. Figure 1 shows an example of a simplified CANopen system and the CAN IDs used by each device.

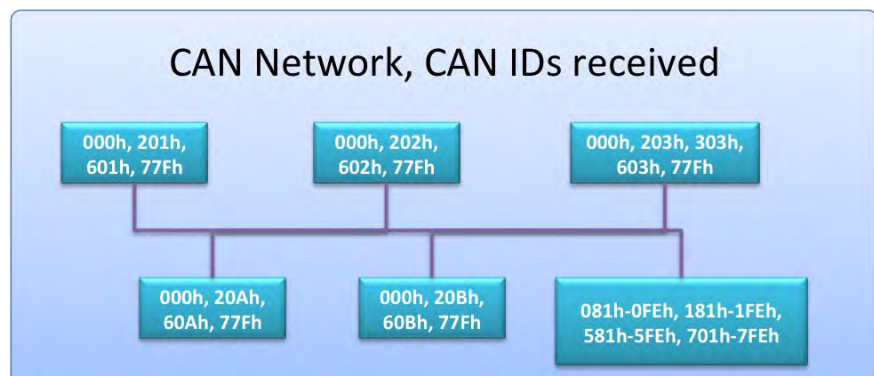

Figure 2: CAN-IDs of received data frames (Source: Emsa)



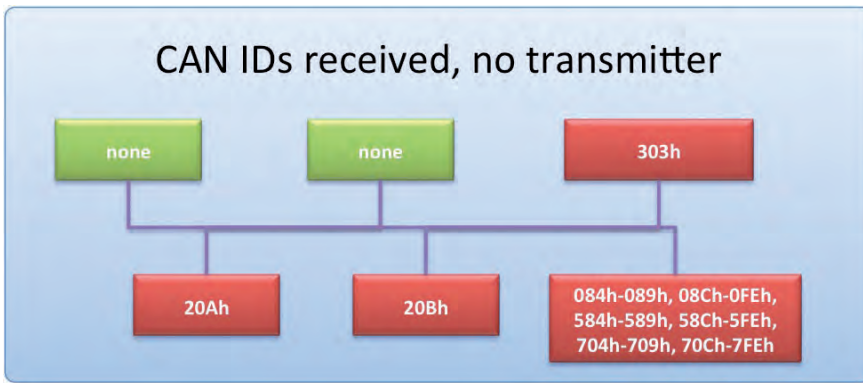

Figure 3: “Unprotected” CAN-IDs (Source: Emsa)

In the scheme, each node applies its known list of CAN IDs used for transmission to a:

- ◆ Whitelist: this node may only use the CAN IDs in the list for transmission.
- ◆ Blacklist: this node monitors the network to ensure that nobody else uses the CAN IDs in the list for transmission.

This process actively protects the system: If a node detects that a CAN ID from its blacklist is used on the network, it assumes that an attack is happening and someone tries to inject this CAN data frame, for example by using a bus sniffer or a hacked node. If equipped with the ability to generate error frames, the protected node can destroy the injected data frame. The CAN ID is protected to only be used by the node, it is assigned to.

### Limitations of blacklist and whitelist handling

As illustrated above, this method ensures that it becomes more difficult to inject CAN data frames. On the receiving side, a CAN data frame with a protected CAN ID can mostly be trusted. Mostly, because there are some attack vectors remaining: if a hacker removes a node either physically or logically by forcing its CAN controller into bus off state, this node no longer protects its CAN IDs. In another scenario, if an attacker hijacks a node, then the attacker can generate any CAN data frames with the CAN IDs that are whitelisted in the node.

Another potential attack vector involves devices, which by default accept CAN data frames from many sources. In CANopen FD for example, devices accept USDO requests from any possible node ID. Not all node IDs will be present in the network, though, so injection attacks using requests assigned to a non-existing node ID will still work.

In order to check a system for remaining injection vulnerabilities, for the whole network you need to verify which CAN IDs are received by the individual devices to determine those CAN IDs that are unprotected. As an example, look at Figure 2, in which all received CAN IDs are shown. Now compare it with Figure 1 that shows all transmit CAN IDs and you will notice that there is a mismatch. This is shown in Figure 3, which has those CAN IDs without a defined transmitter, which are therefore unprotected and still vulnerable to injection.

In this example the device in the bottom right is a CANopen manager where the list of CAN IDs that it can potentially receive is very long.

Even if black and white listing is supported in hardware there can still be serious attack vectors available to intruders, especially if an output device accepts data from many different CAN IDs. Therefore, a true authentication method will still be required for some applications.

For CAN XL, the current plan is to have a 1-byte field to indicate if a data frame transports plain data, protocol-specific data or data that includes a digital signature.

Since CANopen FD is poised to support both CAN FD and CAN XL as data link layers anyway, a parameter will be introduced here to globally set the available data size per frame. In addition to supporting the FD and XL versions of CAN, it will potentially also be used to limit the data portion of the frames available to the protocol to make room for a digital signature or other security data. ◀



#### Authors

Olaf Pfeiffer, Christian Keydel  
Emsa (Embedded Systems Academy)  
[info@esacademy.com](mailto:info@esacademy.com)  
[www.esacademy.de](http://www.esacademy.de)

# Slip rings connect reliably CAN bus-lines

*Especially in construction machine and equipment, slip rings are used to transfer data signals and power to rotating cabs. Intermittent open or high resistance needs to be avoided, to guarantee a reliable signal transmission.*

There are slip rings available, which enable CAN communication with bit-rates up to 1 Mbit/s and above. They achieve this with an excellent Bit Error Rate (BER) over the life of the system. When we refer to BER, we are speaking the “language” of data reliability. A stable, well-formed eye pattern is the most important element of low BER and reliable data transmission. But in the case of electrical contacts, bit errors can also be caused by intermittent open circuits in the transmission line as a result of high (or even open) resistance between the contacting members of electrical contacts. These resistance changes are often called contact noise or sometimes “microcuts.” For example, fretting wear/corrosion can cause resistance in electrical connector pins to go high enough to create intermittent open circuits (bit errors). Slip rings are constructed with sliding electrical contacts where conducting brushes, or wipers, slide along circular conductive ring surfaces to allow electrical contact during rotation.

## Slip rings in construction equipment

Reliable data transmission through slip rings requires control of the conditions that cause closed eye patterns as well as intermittence opens or high resistance. Proper materials, good electrical design, and environmental protection of the sliding contacts accomplish this control. It is important to understand that many of these design aspects are also crucial for the reliable transfer of power, as well as data. For example, the transfer of power on sliding electrical contacts is very dependent upon an enclosure that protects the contacts from the environmental effects of contamination and most especially moisture.

## Proper contact materials and contact design

CAN data transmission through electrical contacts has had a significant impact on the contact materials used to transfer the data. Some contact materials that have been used successfully in the past cannot transmit error-free digital data because of unreliable contact resistance. Contaminants produced by wear debris and surface films can produce high resistance events that produce bit errors. Noble metal electrical contacts should be used for electrical contacts transmitting digital data. These un-reactive (i.e., noble) metals resist corrosion and surface filming thereby providing consistently low contact resistance.

The reliability of electrical contacts is greatly improved with redundancy. Figure 2 shows a ring with a

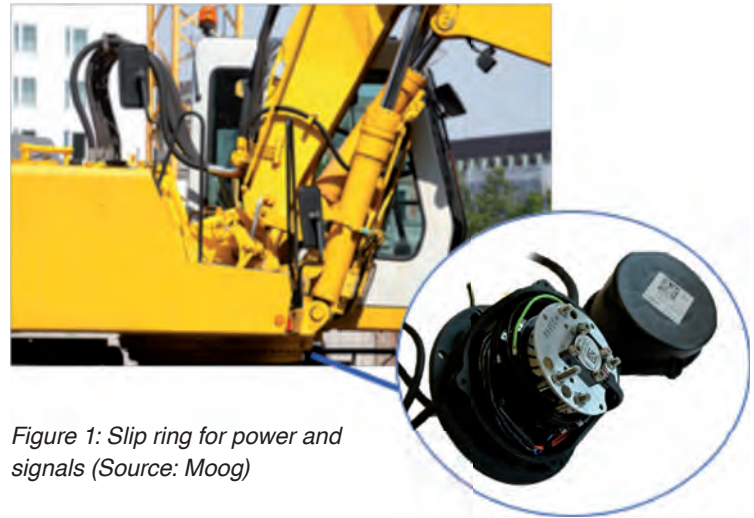

Figure 1: Slip ring for power and signals (Source: Moog)

brush assembly with six independent precious metal contact elements per ring. This redundant contact arrangement virtually eliminates the potential for an anomaly (e.g., contaminating particle) to effect all brushes simultaneously resulting in very low BER ( $10^{-12}$  or better). Proper brush design must also take into account the shock and vibration environment found on construction equipment. Again, redundancy is important as is the contact force and the relative mass of the brush in order to keep the resonant frequency of the brush well above operating excitation frequencies.

## Electrical design for RF

It is generally believed that resistive contact noise (intermittent high resistance events) is the primary limit to slip ring bandwidth. But just as important to reliable data transfer is proper electrical design that does not filter the high frequency components of a digital signal (see Figure 3). Any component (slip ring, connector, relay, etc.) inserted into a digital data transmission line will have an effect on the BER of the data transmission because of the impedance discontinuity or mismatch placed in the data path. The magnitude of the impact on the signal transmission is a function of the length and magnitude of the impedance mismatch as well as any phase imbalance introduced into the transmission line. Connector selection, lead and shield termination, ring and brush impedance, as well as a number of other design and manufacturing considerations, have a significant impact on data reliability. Slip ring engineers who design slip rings to handle communication data must





Figure 2: Ring brush assembly showing six contact elements (Source: Moog)

specify proper internal design features to control the amplitude and length of the impedance mismatch as a function of the data speed and type.

Crosstalk can also be problematic in slip ring design. Placing a number of power and data circuits in relative

close proximity in a housing requires careful attention to the isolation of noise sensitive channels from noise producing channels. Careful physical spacing and shielding accomplish this.

### Environmental protection

Slip rings require a protective housing to protect the sliding electrical contacts from environmental contamination like the one in Figure 4. One of the leading causes of slip ring failure is a breakdown in this environmental protection thereby exposing the exposed electrical contacts to external contamination. Contamination from sand and dust, humidity, or hydraulic oil (to name just a few) can result in failure of data channels. Lack of or degradation of the structural stiffness of the housing can also expose the contacts to excessive amplified vibration levels. Proper slip ring mechanical housing design is just as important to

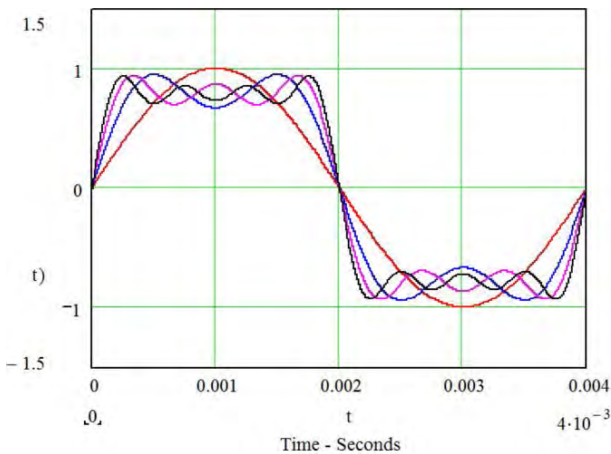

$$\begin{aligned} & \sin(\omega \cdot t) \\ & \sin(\omega \cdot t) + \frac{1}{3} \sin(3\omega \cdot t) \\ & \sin(\omega \cdot t) + \frac{1}{3} \sin(3\omega \cdot t) + \frac{1}{5} \sin(5\omega \cdot t) \\ & \sin(\omega \cdot t) + \frac{1}{3} \sin(3\omega \cdot t) + \frac{1}{5} \sin(5\omega \cdot t) + \frac{1}{7} \sin(7\omega \cdot t) \end{aligned}$$

Figure 3: The ability of the transmission line to pass higher order harmonics improves the quality and reliability of the digital data being transmitted (Source: Moog)



- ▶ Read
- ▶ Write
- ▶ Advertise

## Publications

**CAN Newsletter magazine**  
[www.can-newsletter.org/magazine](http://www.can-newsletter.org/magazine)

- ▶ Technical in-depth articles
- ▶ Market trends
- ▶ Detailed application reports

**CAN Newsletter Online**  
[www.can-newsletter.org](http://www.can-newsletter.org)

- ▶ Product news
- ▶ Brief application reports
- ▶ Tool news

**CIA Product Guides**  
[www.cia-productguides.org](http://www.cia-productguides.org)

- ▶ CANopen & J1939 services
- ▶ CAN tools & devices
- ▶ Protocol stacks

*From experts to experts:  
Address the CAN community  
with your contributions.*

[publications@can-cia.org](mailto:publications@can-cia.org)

data reliability as the design of the electrical contacts or the electrical design. The construction equipment environment can be harsh in terms of shock, vibration, contaminating fluids/sand/dust, and temperature extremes. Critical features of the housing must include:

- ◆ The electromagnetic environment should also be considered. “Contamination” from conducted or radiated electromagnetic noise can result in spurious data coupling onto digital data channels. Proper electromagnetic shielding is an important slip ring feature.
- ◆ An external housing that is rugged and stiff, but not excessively heavy as well as corrosion and fungus resistant.
- ◆ Environmental sealing to the appropriate IP standard, which is normally IP65- or IP66-rated depending on the operating environment
- ◆ A maintenance-free bearing design to survive all environmental requirements
- ◆ The ability to operate within a temperature range of -40 °C to +80 °C and a humidity range between 0 % and 100 %.
- ◆ The housing must survive the shock and vibration levels imposed by construction equipment without significant degradation.

## CAN communication

There is a wide range of protocols or formats used to communicate between devices. Classical CAN is the most commonly used network technology in construction equipment. With a maximum data rate of 1 Mbit/s, data is transmitted differentially on a twisted pair (balanced) from which it derives its robust noise immunity and fault tolerance. The nominal line impedance of CAN is 120 Ohm and the slip ring should be designed with this impedance in mind. Low latency is critical with CAN, but since slip rings are passive devices, they do not contribute to system latency. A variety of multi-pin, environmental connectors can be used as the interface to the CAN channel(s). Properly designed slip rings can reliably transmit CAN data with BER rates of greater than  $10^{-12}$ . The same can be said for CAN FD with a data rate 10 Mbit/s or less.



Figure 4: Slip ring protective housing (Source: Moog)

### Bit Error Rate (BER)

Bit Error rate is the best metric of quality of digital data and values on the order of  $10^{-9}$  are normally required for acceptable data transmission, i.e, one bit out of every 1 billion is “bad” or one bit error every 10 seconds for data transmitted at 100 Mbit/s. A signal can be assessed for potential data quality by looking at its eye pattern. The figure shows the eye pattern of a 100 Mbit/s square wave. “Stacking up” all the pulses on a transmission line on top of each other forms the eye patterns, to clearly see the pulse amplitude and phase variation. The open part, or eye, can be equated to a BER value. Smaller eyes equal higher BERs, or poorer data quality. Eye patterns show the quality of the transmission line being used to transmit the signal and are a very good indicator of the impedance mismatch in the transmission line.

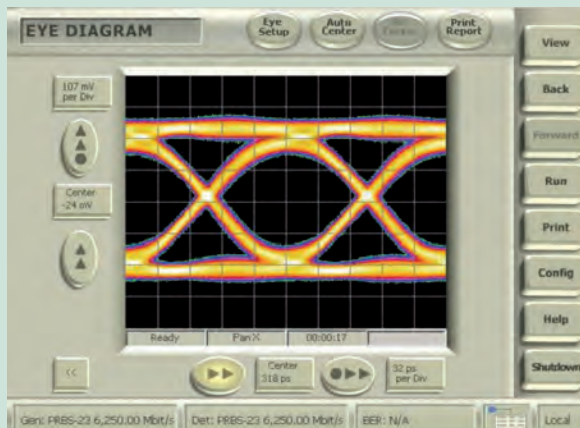

Eye diagram (Source: Moog)



### Authors

Glenn Dorsey  
 Moog  
 Christoph Daun  
 Moog Rekofa  
[www.moog.com](http://www.moog.com)  
[www.rekofa.net](http://www.rekofa.net)



## Products for mobile automation



### Maximum reliability for extreme conditions

If there is one thing we know after many years of experience with sensors and control systems:

Products used in mobile machines must be extremely robust. Exposed to heat, cold, moisture, dust and vibrations, they must guarantee maximum reliability – even if the going gets tough. This is why we offer corresponding solutions for operation, communication and remote maintenance. The result: increased uptime and maximum reliability of your machines. ifm – close to you!



Go ifm online  
[ifm.com/gb/mobile](http://ifm.com/gb/mobile)





*CAN in Automation*

The non-profit CiA organization promotes CAN and CAN FD, develops CAN FD recommendations and CANopen specifications, and supports other CAN-based higher-layer protocols such as J1939-based approaches.

## *Join the community!*

- ▶ Initiate and influence CiA specifications
- ▶ Get credits on CiA training and education events
- ▶ Download CiA specifications, already in work draft status
- ▶ Get credits on CiA publications
- ▶ Receive the exclusive, monthly CiA Member News (CMN) email service
- ▶ Get CANopen vendor-IDs free-of-charge
- ▶ Participate in plugfests and workshops
- ▶ Get the classic CANopen conformance test tool
- ▶ Participate in joint marketing activities
- ▶ Develop partnerships with other CiA members
- ▶ Get credits on CiA testing services

*For more details please contact CiA office  
at [headquarters@can-cia.org](mailto:headquarters@can-cia.org)*

*[www.can-cia.org](http://www.can-cia.org)*