

## EE Architecture exploration for multiple Bus at FGA using a simulation tool

Ignazio Amato, Francesco D'Alessandro, FGA

Increasing EE contents and features in FGA vehicles, lead to high CAN Bus load. Many more CAN messages have to be transmitted, with hard timing requirements in terms of periodicity and maximum latency time. Managing in a proper way messages priorities, offset values and launch types, improves CAN Bus performances, but can be no longer sufficient by itself to meet the increased timing requirements. In this paper it is described the new approach developed by FGA in order to optimize system performances. The new method is based on a detailed definition of functional and timing requirements. A simulation tool has been used to explore a variety of potential new multiple-CAN EE architectures.

The Electrical Electronic Architecture (EEA) represents the core system in modern vehicles. It is based on real time system of EEA characterized by multiplexed communication channels, in which the information between the Electronic Control Units (ECUs) have to be exchanged in the right way and with the right timing; this is very relevant for all the vehicle functionalities.

For what concerns CAN Bus, key performance indicators are Bus Load (BL) and message latency time. BL indicates the average bandwidth usage of the communication channel; it is expressed as a percentage value. Message latency time gives the indication of the delay that each CAN message takes while the sender ECU is performing Bus contention; it is expressed in [ms].

With very low BL value (i.e. less than 30%) the message latencies are low and scarcely relevant. Let consider an EEA topology with a low speed subnet (50Kbps) and a high speed subnet (500Kbps) in which there are 10 ECUs and 25 messages, as depicted in figure 1:

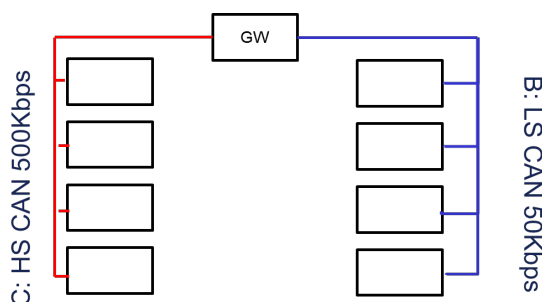

Figure 1: Basic EEA topology

the resultant bus load for the high speed subnet is equal to 32% and the Quality Index, that indicates the maximum latency detected as a percentage of the CAN Message periodicity, is equal to 8%.

The Automotive market trend leads Car makers to introduce in the vehicles many more Infotainment and Powertrain/Chassis contents and so a lot of new ECUs and CAN messages have to be added in the CAN Bus; this affects the BL value.

The more BL increases the more message latency grows in a no-linear way; during Network Designing, a particular attention is needed, in order to minimize latency issues in spite of a high usage of the CAN Bus.

Results obtained by laboratory testing (timing analysis) have highlighted that, when BL overcomes 60% of available bandwidth, it is recommended to pay more attention in the definition and calibration of the following relevant parameters of the CAN Bus transmission: Message IDs, Message Periodicity and Offset. The last one shall be a mandatory requirement, since only managing in the right way this parameter, a good results in terms of message latencies, are achievable.

These design activities have been performed in the EEA topology shown in Figure 2, with a mid speed subnet (125Kbps) and a high speed subnet (500 Kbps) in which BL value is equal to 70% and the Quality Index was improved from 70% to 30% managing offset values:

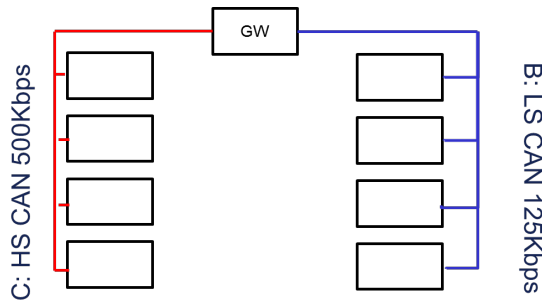

Figure 2: Medium EEA topology

**OFFSET Management**

The offset values allow spreading messages transmission scheduling of each ECU in order to avoid bursts on the Bus; the bursts are responsible for the accumulation of messages delay in the ECU output message buffer.

Several viable ways to define offset parameter are described in literature and implemented by different car makers. In our applications it has been considered an offset assignment rule focused on the optimization of message transmission of the single ECU instead of optimizing the messages transmission scheduling of the entire bus system. In this way if we were forced to change the number of the messages transmitted by the single ECU, we would not have the need to modify OFFSET values in the remaining ECUs saving project development timing and costs. The offset assignment rule can be expressed as

$$OFFSET(i) = \text{round}[(P/2N + i \cdot P/N) / Res] / Res$$

with  $0 \leq i \leq n-1$

where

- OFFSET(i) is the offset value for the i-message
- P is message periodicity
- N is the number of messages sent by an ECU
- Res is the offset resolution that the ECU is able to manage (strictly related to the ECU framing processing period)

It has been observed that there is great benefit to respect the right relationships between message priority, message periodicity and offset as shown in the figure 4:

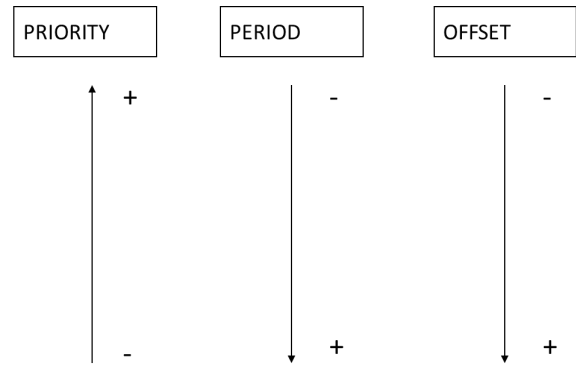

Figure 4: Priority vs Period vs OFFSET

For example: considering an ECU that has to send 5 messages, Message A, B and C with a periodicity equal to 10 ms and Message D and E with a periodicity equal to 100ms, the related OFFSET values will have to be assigned as represented in Table 1:

Messages	Priority [dec]	Period [ms]	Offset [ms]
Message A	1	10	2
Message B	2	10	4
Message C	3	10	8
Message D	4	100	24
Message E	5	100	76

Table 1: Offset assignment

The figure 3 shows the benefits in terms of latencies reduction, carried out applying the offset management, considering the EEA topology in Figure 2:

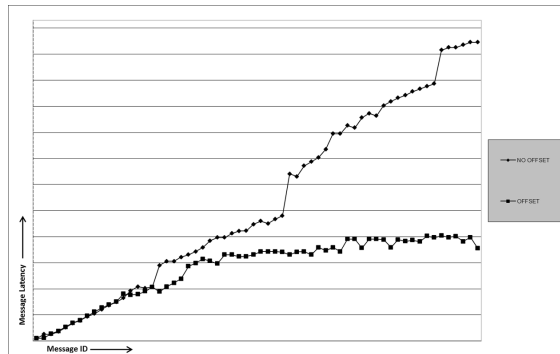

Figure 3: Latencies Vs Message priorities

**EEA exploration**

In case of very high BL values (i.e. more than 80%), a proper management of CAN Bus Transmission parameters, could be no longer enough; a topology change of the EEA would be needed. To do that, it is necessary to add new CAN subnets, modify the respective baud rates, re-define the ECUs allocation and evaluate the possibility to have some ECUs connected to more than one bus, especially if they are capable to support gateway/routing functionality; in the message oriented approach, changing the topology means to define new signal-to-message mapping as well.

Having as target the design of a brand new EEA, minimizing the BL of each subnet, it has been developed a dedicated tool that is able to define the optimal characteristics of EEA topology also in terms of CAN message latencies. More specifically, the tool gives, as result, the ECUs allocation, the gateway/router roles and the signal-to-message mapping. As an input, the tool needs the ECU list, the signals communication matrix and, for each signal, timing constraints in terms of maximum delay, during the bus contention (Scheduling Latency-SL).

In Table 2 it is reported input file layout:

Table 2: Signal communication Matrix

Signals	ECU 1	ECU 2	ECU X	P [ms]	Max SL
Signal 1	Tx	Rx		10	2
Signal 2	Rx		Tx	10	2
Signal 3	Rx	Tx	Rx	50	15
Signal 4		Tx	Rx	100	30
Signal x		Rx	Tx	1000	150

As it is well known, the SL is only a part of the entire delay that the signal accumulates in the path between sensor and actuator (Maximum Age). See Figure 4:

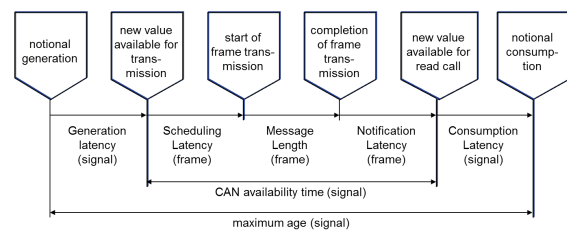

Figure 4: Maximum age

Starting from the functionalities performance requirements (Maximum Age) and assuming that Generation Latency, Message Length, Notification Latency and Consumption Latency are known, it is possible to obtain the SL deadline allowed for each signal.

Generation Latency is the time that the ECU takes to generate the signal value, starting from the sensor input; this value has to be provided by the sender ECU supplier.

Message Length is strictly related to the baud rate and Data Length Code of the transmitted message.

Notification Latency is the time that the receiver ECU takes to process the received message (availability of the information to the application layer); this value has to be provided by the receiver ECU supplier.

Consumption Latency is the time that the actuator takes to consume the information; this value has to be provided by the actuator supplier.

For this aim a strong synergy with Tiers-1 is very important in terms of design data sharing.

**Tool analysis results**

As a starting point of the analysis conducted, an EEA, having a high speed subnet with a baud rate equal to 500Kbps and a mid-speed subnet with a baud rate equal to 125 Kbps, has been considered as depicted in Figure 2, with a greater number of contents, functionalities and ECUs (29bit IDs) than the initial one. Running timing analysis, it has been obtained the results, in terms of BL and Quality Index as shown in the Table 3:

*Table 3: Initial EEA topology. High and Medium speed CAN subnet performances*

	Subnet 1	Subnet 2
#ECU	16	10
# ECU on both	1	1
# Messages	98	70
BL [%]	92	60
Quality Index [%]	>100	70

This so high BL value has led to try to obtain different solutions in terms of EEA topologies.

It has been provided to the tool, as an input, the ECUs, signals and timing constraints of the initial EEA, defining in addition the ECU having more than one CAN interface availability. No constraints have been given to the tool about the maximum number of subnets. After several explorations, the best EEA topologies in terms of BUS performances have been selected.

First: In Figure 5 it is presented the EEA topology having 2 High Speed Subnets with a baud rate equal to 500 Kbps, an ECU that is also the Gateway node and 3 ECUs (with no gateway functionality) connected to both subnets, 11 bit IDs. It has been considered only Powertrain and Chassis ECUs present in the initial EEA. In the table 4 the results in details.

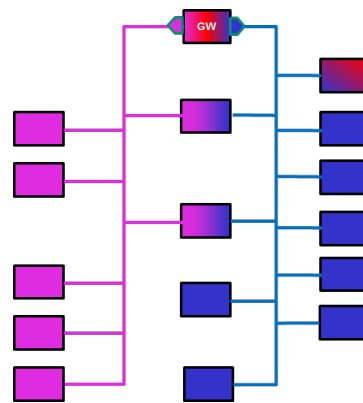
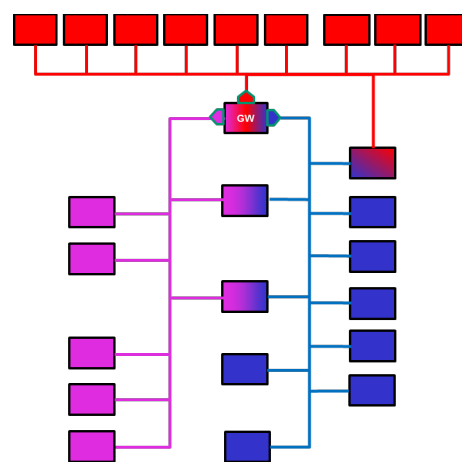

*Figure 5: 2 High speed CAN subnet topology*

*Table 4: 2 High speed CAN subnet topology performances*

	Subnet 1	Subnet 2
#ECU	10	7
# ECU on both	4	4
# Messages	43	48
BL [%]	39	34
Quality Index [%]	20	15

Second: In Figure 6 is presented EEA topology having 3 High Speed Subnets with a baud rate equal to 500 Kbps, an ECU that is also the Gateway node and 5 ECUs (with no gateway functionality) connected to more than one subnet, 11 bit IDs. It has been considered Powertrain, Chassis and Body/Infotainment ECUs present in the initial EEA. In the table 5 the results in details.



*Figure 6: 3 High speed CAN subnet topology*

Table 5: Three High speed CAN subnet topology performances

	Subnet 1	Subnet 2	Subnet 3
#ECU	10	8	6
# ECU on more than one BUS	2	2	
	2		2
	1	1	1
# Messages	67	55	56
BL [%]	43	36	33
Quality Index [%]	30	20	15

Third: In Figure 7 is presented EEA topology having 4 High Speed Subnets with a baud rate equal to 500 Kbps, a dedicated ECU for the Gateway functionality and 6 ECUs (with no gateway functionality) connected to more than one subnet, 11 but IDs. It has been considered Powertrain, Chassis and Body/Infotainment ECUs present in the initial EEA. In the table 6 the results in details.

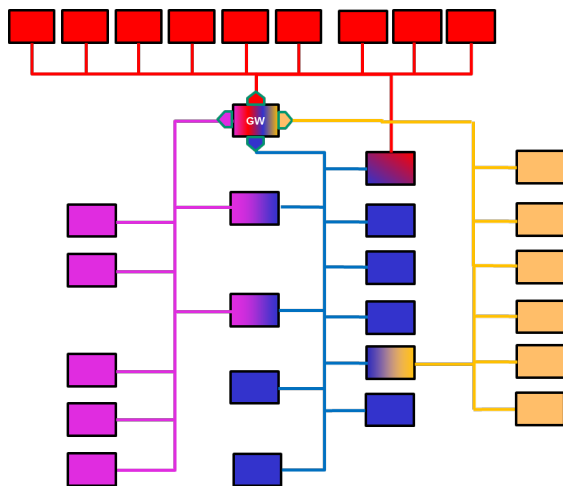

Figure 7: 4 High speed CAN subnet topology

Table 6: Four High speed CAN subnet topology performances

	Subnet 1	Subnet 2	Subnet 3	Subnet 4
#ECU	9	8	6	5
# ECU on more than one BUS	2	2		
	1		1	
		2		2
			1	1
# Messages	41	75	34	50
BL [%]	34	43	33	25
Quality Index [%]	17	32	15	12

All the topologies given by the tool, as an output result, have an improved CAN BUS performance but more subnets and CAN interfaces for some ECUs are needed, with cost increasing.

A specific focus should be done on Gateway node. In Table 7 it is shown the strict relationship between the number of the subnets and the number of gated messages.

Table 7: Gated messages

	Topology with 1 Subnet	Topology with 2 Subnet	Topology with 3 Subnet
# Gateway Messages	8	53	78
Gateway node	No dedicated ECU Gateway	No dedicated ECU Gateway	Dedicated ECU Gateway (Central Gateway)

Dedicated ECU Gateway, in the third topology, allows having High-Performance gateway functionality in order to avoid introducing any further delays in the

transmission of the signals between different subnets.

In case of more than 2 CAN Bus, another issue to address is related the diagnostic functionalities. Some diagnostic tools are not able to simultaneously access (SW/HW limits) to more than 2 CAN Bus for diagnostic communication with the system. In order to provide access to the diagnostic functionalities for all the ECUs, a diagnostic gateway has to be introduced. It could be implemented as introducing this feature in the already present gateway node of the EEA topology as with a dedicated diagnostic gateway ECU.

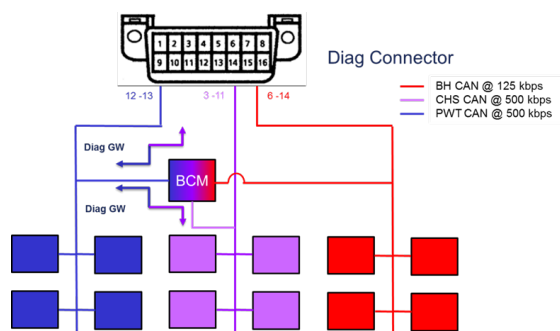

Figure 8: Diagnostic gateway

## Conclusions

At the end of the research activity, it has been achieved a specific Communication Network Design approach, strongly dependent from the BL value and message latency time. See Figure 9:

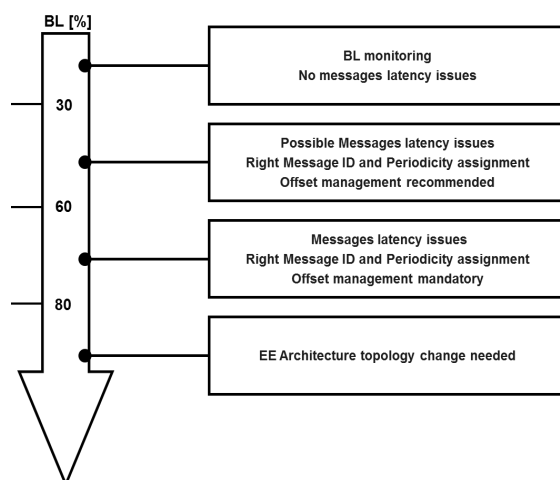

Figure 9: New network design approach

Applying the methodology described in this article, 3 new EEA topologies have been obtained with a relevant improvement of the BUS performances respect to the initial one.

These 3 new architectures are viable as the off-the-shelf solutions for the new programs to cover all the vehicle segments.

---

Ignazio Amato

FGA

Corso Settembrini, 40

IT-10135 Turin

Tel.: +390110037987

ignazio.amato@fiat.com

---

Francesco D'Alessandro

FGA

Corso Settembrini, 40

IT-10135 Turin

Tel.: +390110037398

francesco.dalessandro@fiat.com